

harman/kardon

# AVR125

A/V DOLBY DIGITAL RECEIVER

## SERVICE MANUAL



### CONTENTS

ESD WARNING.....	2	AMPLIFIER BIAS ADJUSTMENT.....	21
LEAKAGE TESTING.....	3	TECH TIP HKTT2003-01.....	22
BASIC SPECIFICATIONS.....	4	TECH TIP HKTT2004-03.....	23
FRONT PANEL CONTROLS.....	5	BLOCK DIAGRAM.....	27
FRONT PANEL DISPLAY.....	7	IC PINOUTS.....	28
REAR PANEL CONNECTIONS.....	9	TRANSISTOR PINOUTS.....	57
REMOTE CONTROL FUNCTIONS.....	11	ELECTRICAL PARTS LIST.....	58
INSTALLATION AND CONNECTIONS.....	14	PCB DRAWINGS.....	67
TROUBLESHOOTING GUIDE.....	16	SCHEMATICS.....	75
MICROPROCESSOR RESET.....	16	WIRING DIAGRAM.....	87
UNIT EXPLODED VIEW.....	17	PACKAGING.....	88
DISASSEMBLY PROCEDURE.....	18		

harman/kardon, Inc.  
250 Crossways Park Dr.  
Woodbury, New York 11797

Rev6 11/2005

## ELECTROSTATICALLY SENSITIVE (ES) DEVICES

Some semiconductor (solid state) devices can be damaged easily by static electricity. Such components commonly are called Electrostatically Sensitive (ES) Devices. Examples of typical ES devices are integrated circuits and some field effect transistors and semiconductor "chip" components.

The following techniques should be used to help reduce the incidence of component damage caused by static electricity.



1. Immediately before handling any semiconductor component or semiconductor-equipped assembly, drain off any electrostatic charge on your body by touching a known earth ground. Alternatively, obtain and wear a commercially available discharging wrist strap device, which should be removed for potential shock reasons prior to applying power to the unit under test.
2. After removing an electrical assembly equipped with ES devices, place the assembly on a conductive surface such as aluminum foil, to prevent electrostatic charge build-up or exposure of the assembly.
3. Use only a grounded-tip soldering iron to solder or unsolder ES devices.
4. Use only an anti-static solder removal device. Some solder removal devices not classified as "anti-static" can generate electrical charges sufficient to damage ES devices.
5. Do not use freon-propelled chemicals. These can generate electrical charge sufficient to damage ES devices.
6. Do not remove a replacement ES device from its protective package until immediately before you are ready to install it. (Most replacement ES devices are packaged with leads electrically shorted together by conductive foam, aluminum foil or comparable conductive material.)
7. Immediately before removing the protective material from the leads of a replacement ES device, touch the protective material to the chassis or circuit assembly into which the device will be installed.

**CAUTION** : Be sure no power is applied to the chassis or circuit, and observe all other safety precautions.

8. Minimize bodily motions when handling unpackaged replacement ES devices. (Otherwise harmless motion such as the brushing together of your clothes fabric or the lifting of your foot from a carpeted floor can generate static electricity sufficient to damage an ES devices.

## PRODUCT SAFETY NOTICE

Each precaution in this manual should be followed during servicing.

Components identified with the IEC symbol  in the parts list are special significance to safety. When replacing a component identified with , use only the replacement parts designated, or parts with the same ratings or resistance, wattage, or voltage that are designated in the parts list in this manual. Leakage-current or resistance measurements must be made to determine that exposed parts are acceptably insulated from the supply circuit before returning the product to the customer.

## SAFETY PRECAUTIONS

The following check should be performed for the continued protection of the customer and service technician.

### LEAKAGE CURRENT CHECK

Measure leakage current to a known earth ground (water pipe, conduit, etc.) by connecting a leakage current tester between the earth ground and all exposed metal parts of the appliance (input/output terminals, screwheads, metal overlays, control shaft, etc.). Plug the AC line cord of the appliance directly into a 120V AC 60Hz outlet and turn the AC power switch on. Any current measured must not exceed 0.5mA.

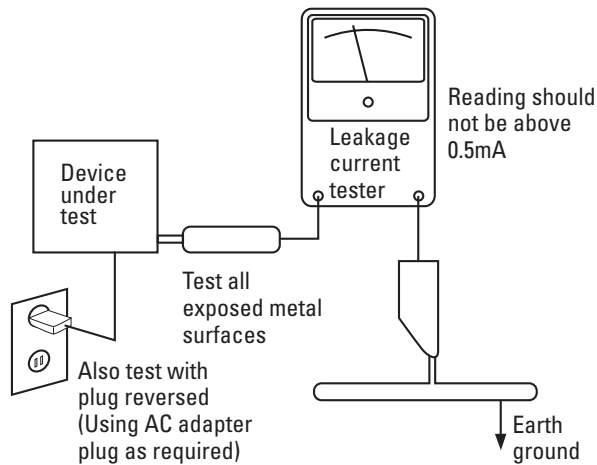

### AC Leakage Test

**ANY MEASUREMENTS NOT WITHIN THE LIMITS OUTLINED ABOVE ARE INDICATIVE OF A POTENTIAL SHOCK HAZARD AND MUST BE CORRECTED BEFORE RETURNING THE APPLIANCE TO THE CUSTOMER.**

**Audio Section**

Stereo Mode

Continuous Average Power (FTC)

55 Watts per channel, @ < 0.07% THD, 20Hz – 20kHz,  
both channels driven into 8 ohms

Five-Channel Surround Modes

Power Per Individual Channel

Front L&amp;R channels:

45 Watts per channel

@ &lt; 0.07% THD, 20Hz–20kHz into 8 ohms

Center channel:

45 Watts @ &lt; 0.07% THD, 20Hz–20kHz into 8 ohms

Surround channels:

45 Watts per channel

@ &lt; 0.07% THD, 20Hz–20kHz into 8 ohms

Input Sensitivity/Impedance

Linear (High-Level) 200mV/47k ohms

Signal-to-Noise Ratio (IHF-A) 95dB

Surround System Adjacent Channel Separation

Pro Logic II 45dB

Dolby Digital (AC-3) 55dB

DTS 55dB

Frequency Response

@ 1W (+0dB, –3dB) 10Hz–100kHz

High Instantaneous

Current Capability (HCC) ±25 Amps

Transient Intermodulation

Distortion (TIM) Unmeasurable

Slew Rate 40V/μsec

**FM Tuner Section**

Frequency Range	87.5–108.0MHz
Usable Sensitivity	IHF 1.3μV/13.2dBf
Signal-to-Noise Ratio	Mono/Stereo 70dB/68dB
Distortion	Mono/Stereo 0.2%/0.3%
Stereo Separation	40dB @ 1kHz
Selectivity	±400kHz, 70dB
Image Rejection	80dB
IF Rejection	90dB

**AM Tuner Section**

Frequency Range	520–1710kHz
Signal-to-Noise Ratio	45dB
Usable Sensitivity	Loop 500μV
Distortion	1kHz, 50% Mod 0.8%
Selectivity	±10kHz, 30dB

**Video Section**

Television Format	NTSC
Input Level/Impedance	1Vp-p/75 ohms
Output Level/Impedance	1Vp-p/75 ohms
Video Frequency Response	10Hz–8MHz (–3dB)

**General**

Power Requirement	AC 125V/60Hz
Power Consumption	68W idle, 540W maximum (2 channels driven)

Dimensions

Width	17.3 inches (440mm)
Height	6.6 inches (168mm)
Depth	15.4 inches (390mm)

Weight 23.8 lb (10.8kg)

Depth measurement includes knobs, buttons and terminal connections.

Height measurement includes feet and chassis.

All features and specifications are subject to change without notice.

Harman Kardon is a registered trademark, and Power for the Digital Revolution is a trademark,  
of Harman Kardon, Inc.

\*Manufactured under license from Dolby Laboratories.

Dolby, Pro Logic II, AC-3 and the Double-D symbol are  
trademarks of Dolby Laboratories. Confidential Unpublished  
Works. ©1992–1999 Dolby Laboratories, Inc. All rights reserved.

DTS and DTS Surround are registered trademarks of Digital Theater Systems, Inc.

UltraStereo is a trademark of UltraStereo Corp.

VMAx is a registered trademark of Harman International Industries, Inc., and is an  
implementation of Cooper Bauck Transaural Stereo under patent license.

Logic 7 is a registered trademark of Lexicon, Inc., a Harman International Company.

Crystal is a registered trademark of Cirrus Logic Corp.

## FRONT-PANEL CONTROLS

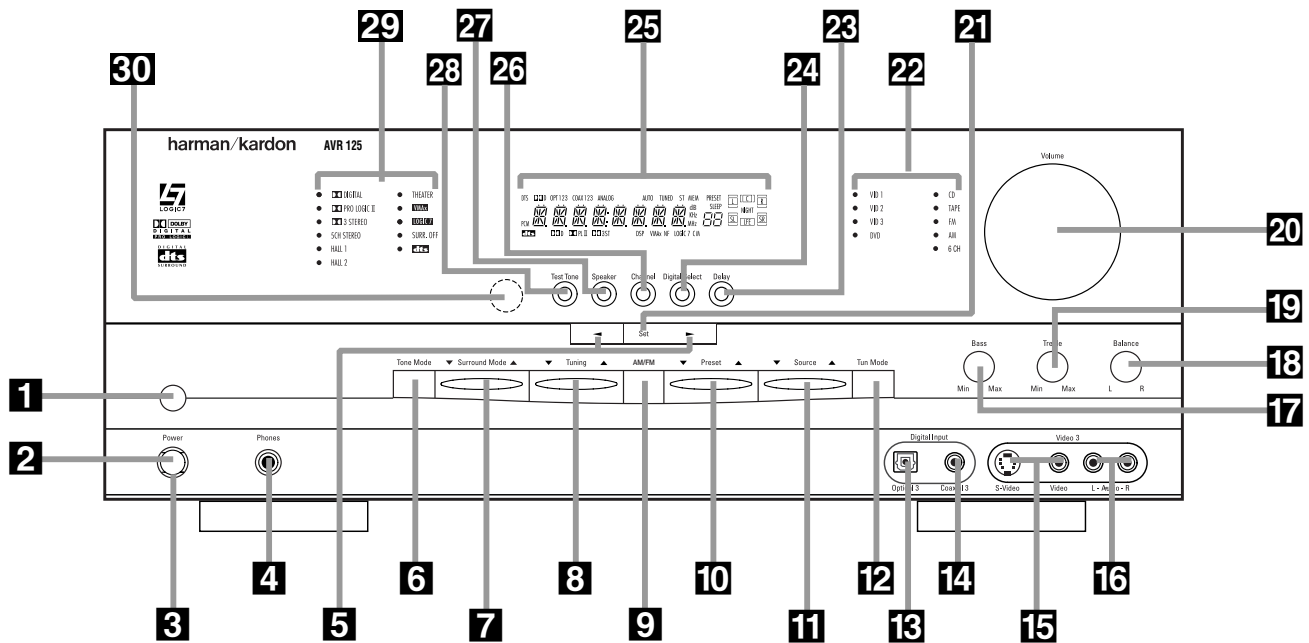

- |                                    |                                     |                                    |
|------------------------------------|-------------------------------------|------------------------------------|
| <b>1</b> Main Power Switch         | <b>11</b> Input Source Selector     | <b>21</b> Set Button               |
| <b>2</b> System Power Control      | <b>12</b> Tuning Mode Selector      | <b>22</b> Input Indicators         |
| <b>3</b> Power Indicator           | <b>13</b> Digital Optical 3 Input   | <b>23</b> Delay                    |
| <b>4</b> Headphone Jack            | <b>14</b> Digital Coax 3 Input      | <b>24</b> Digital Input Selector   |
| <b>5</b> Selector Buttons          | <b>15</b> Video 3 Video Input Jacks | <b>25</b> Main Information Display |
| <b>6</b> Tone Mode                 | <b>16</b> Video 3 Audio Input Jacks | <b>26</b> Channel Select Button    |
| <b>7</b> Surround Mode Selector    | <b>17</b> Bass Control              | <b>27</b> Speaker Select Button    |
| <b>8</b> Tuning Selector           | <b>18</b> Balance Control           | <b>28</b> Test Tone Selector       |
| <b>9</b> AM/FM Selector            | <b>19</b> Treble Control            | <b>29</b> Surround Mode Indicators |
| <b>10</b> Preset Stations Selector | <b>20</b> Volume Control            | <b>30</b> Remote Sensor Window     |

**1 Main Power Switch:** Press this button to apply power to the AVR 125. When the switch is pressed in, the unit is placed in a Standby mode, as indicated by the amber LED **3** surrounding the **System Power Control 2**. This button **MUST** be pressed in to operate the unit. To turn the unit off and prevent the use of the remote control, this switch should be pressed until it pops out from the front panel so that the word "OFF" may be read at the top of the switch.

**NOTE:** This switch is normally left in the "ON" position.

**2 System Power Control:** When the **Main Power Switch 1** is "ON," press this button to turn on the AVR 125; press it again to turn the unit off. Note that the **Power Indicator 3** surrounding the switch will turn green when the unit is on.

**3 Power Indicator:** This LED will be illuminated in amber when the unit is in the Standby mode to signal that the unit is ready to be turned on. When the unit is

in operation, the indicator will turn green. Should the indicator turn red, turn the unit off using the **Main Power Switch 1** and check the speaker wire connections to make certain that there are no short circuits.

**4 Headphone Jack:** This jack may be used to listen to the AVR 125's output through a pair of headphones. Be certain that the headphones have a standard 1/4" stereo phone plug. The speakers will automatically be turned off when the headphone jack is in use.

**5 Selector Buttons:** When you are establishing the AVR 125's configuration settings, use these buttons to select from the choices available, as shown in the **Main Information Display 25**.

**6 Tone Mode:** Pressing this button enables or disables the Bass and Treble tone controls. When the button is pressed so that the words **TONE IN** appear in the **Main Information Display 25**, the

settings of the **Bass 17** and **Treble 19** controls may be used to adjust the output signals. When the button is pressed once or twice so that the words **TONE OUT** appear in the **Main Information Display 25**, the output signal will be "flat," without any bass or treble alteration, no matter how the actual **Bass and Treble Controls 17/19** are adjusted.

**7 Surround Mode Selector:** Press this button to change the surround mode by scrolling through the list of available modes. Depending on the type of input, some modes are not always available. (See page 22 for more information about surround modes.)

**8 Tuning Selector:** Press the left side of the button to tune lower-frequency stations and the right side of the button to tune higher-frequency stations. When a station with a strong signal is reached, the **TUNED Indicator Q** will be illuminated in the **Main Information Display 25**.

## FRONT - PANEL CONTROLS

In Manual tuning mode, tap the button lightly and note that the tuner will step up one frequency increment per button press. When the button is held for a few seconds you will note that the unit will quickly advance through the frequency band. Release it and the tuner will stop. In Auto tuning mode, each press of the button will search for the next station with an acceptable signal. Press and hold the button to skip through the acceptable stations. When the button is released, the tuner will not stop until it reaches a station with an acceptable frequency.

To switch back and forth between the Auto and Manual tuning modes, press the **Tuning Mode Selector 12**.

**9 AM/FM Selector:** Pressing this button will automatically switch the AVR 125 to the Tuner mode. Pressing it again will switch between the AM and FM frequency bands. (See page 25 for more information on the tuner.)

**10 Preset Stations Selector:** Press this button to scroll up or down through the list of stations that have been entered into the preset memory. (See page 25 for more information on tuner presets.)

**11 Input Source Selector:** Press this button to change the input by scrolling up or down through the list of **Input Indicators 22**.

**12 Tuning Mode Selector:** Press this button to select Auto or Manual tuning. When the button is pressed so that the **AUTO Indicator R** lights, the tuner will search for the next station with an acceptable signal when the **Tuning Selector 8 21** is pressed. When the button is pressed so that the **AUTO Indicator R** is not lit, each press of the **Tuning Selector 8 21** will increase the frequency. This button may also be used to switch between Stereo and Mono modes for FM radio reception. When weak reception is encountered, press the button until the **STEREO Indicator P** goes out to switch to Mono reception. Press and hold again to switch back to STEREO mode. (See page 25 for more information on using the tuner.)

**13 Digital Optical 3 Input:** Connect the optical digital audio output of an audio or video product to this jack. When the input is not in use, be certain to keep the plastic cap installed to avoid dust contamination that might degrade future performance.

**14 Digital Coax 3 Input:** This jack is used for connection to the output of portable audio devices, video game consoles or other products that have a coax digital audio jack.

**15 Video 3 Video Input Jacks:** These jacks may be used for temporary connection to the composite or S-Video output of video games, camcorders or other portable video products.

**16 Video 3 Audio Input Jacks:** These audio jacks may be used for temporary connection to video games or portable audio/video products such as camcorders and portable audio players.

**17 Bass Control:** Turn this control to modify the low-frequency output of the left/right channels by as much as  $\pm 10\text{dB}$ , when the unit is in the "Surround Off" mode. Set this control to a suitable position for your taste or room acoustics.

**18 Balance Control:** Turn this control to change the relative volume for the front left/right channels.

**NOTE:** For proper operation of the surround modes this control should be at the midpoint or "12 o'clock" position.

**19 Treble Control:** Turn this control to modify the high frequency output of the left/right channels by as much as  $\pm 10\text{dB}$ , when the unit is in the "Surround Off" mode. Set this control to a suitable position for your taste or room acoustics.

**20 Volume Control:** Turn this knob clockwise to increase the volume, counterclockwise to decrease the volume. If the AVR 125 is muted, adjusting the **Volume Control 20 43** will automatically release the unit from the silenced condition.

**21 Set Button:** When making choices during the setup and configuration process, press this button to enter the desired setting as shown in the **Main Information Display 25** into the AVR 125's memory. The set button may also be used to change the display brightness. (See page 26.)

**22 Input Indicators:** A green LED will light in front of the input that is currently being used as the source for the AVR 125.

**23 Delay:** Press this button to begin the sequence of steps required to enter delay time settings. (See page 19 for more information on delay times.)

**24 Digital Input Selector:** When playing a source that has a digital output, press this button to select between the **Optical 13 22** and **Coaxial 14 19** Digital inputs or to select the source's analog input. (See pages 23–25 for more information on digital audio.)

**25 Main Information Display:** This display delivers messages and status indications to help you operate

the receiver. (See pages 7–8 for a complete explanation of the Information Display.)

**26 Channel Select Button:** Press this button to begin the process of trimming the channel output levels using an external audio source. (For more information on output level trim adjustment, see page 25.)

**27 Speaker Select Button:** Press this button to begin the process of configuring the unit to match the type of speakers used in your listening room. (See pages 16–19 for more information on speaker setup and configuration.)

**28 Test Tone Selector:** Press this button to begin the process of adjusting the channel output levels using the internal test tone as a reference. (For more information on output level adjustment, see page 18.)

**29 Surround Mode Indicators:** A green LED will light in front of the surround mode that is currently in use.

**30 Remote Sensor Window:** The sensor behind this window receives infrared signals from the remote control. Aim the remote at this area and do not block or cover it.



# FRONT-PANEL INFORMATION DISPLAY

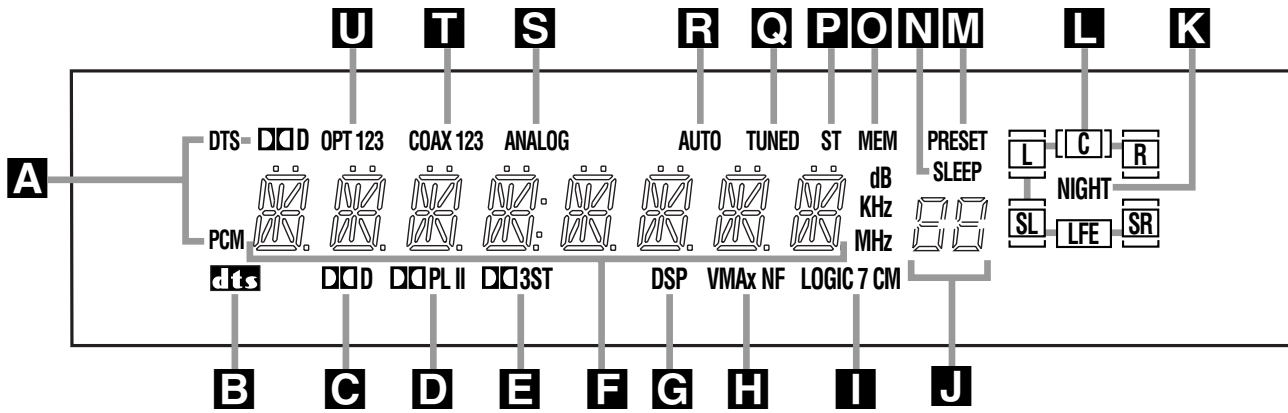

- A** Bitstream Indicators
- B** DTS Mode Indicator
- C** Dolby Digital Indicator
- D** Dolby Pro Logic II Indicator
- E** Dolby 3 Stereo Indicator/Stereo Indicator
- F** Main Information Display
- G** DSP Mode Indicator
- H** VMAx Mode Indicators
- I** Logic 7 Mode Indicators
- J** Preset Number/Sleep Timer
- K** Night Mode Indicator
- L** Speaker/Channel Input Indicators
- M** Preset Indicator
- N** Sleep Indicator
- O** Memory Indicator
- P** Stereo Indicator
- Q** Tuned Indicator
- R** Auto Indicator
- S** Analog Input Indicator
- T** Coaxial Digital Input Indicators
- U** Optical Digital Input Indicators

**A Bitstream Indicators:** When the input is a digital source, one of these indicators will light to display the specific type of data signal in use.

**B DTS Mode Indicator:** This indicator lights when a DTS-encoded source is playing and DTS Surround decoding is in use.

**C Dolby Digital Indicator:** This indicator lights when a Dolby Digital source is being played and Dolby Digital surround decoding is in use.

**D Dolby Pro Logic II Indicator:** This indicator lights when the Dolby Pro Logic II mode has been selected.

- It is possible to see the Dolby Pro Logic II indicator lit simultaneously with the Dolby Digital indicator, even though the Dolby Digital surround mode has been selected. This is due to the specifications for Dolby Digital processing, which require that the Dolby Pro Logic II mode be used any time a 2-channel Dolby signal is detected.

- If you desire 5.1-channel audio, check the audio settings in the menus for both your DVD player and your DVD disc to make sure that a 5.1-channel Dolby Digital sound track is available and has been selected.

**E Dolby 3 Stereo Indicator/Stereo Indicator:** The entire indicator lights when the Dolby 3 Stereo mode has been selected. When the surround modes are turned off so that two-channel stereo playback is in use, only the “ST” indicator will light.

**F Main Information Display:** This display shows messages relating to the status, input source, surround mode, tuner, volume level or other aspects of the AVR 125’s operation.

**G DSP Mode Indicator:** This indicator lights when any of the surround modes created by Digital Signal Processing, or DSP are in use. These modes include Hall 1, Hall 2, Theater and 5-Channel Stereo.

**H VMAx Mode Indicators:** This indicator lights when the VMAx mode is in use. **VMAx F** appears when the Far Field VMAx mode is selected; **VMAx N** appears when the Near Field VMAx mode is selected. (See page 22 for a description of the VMAx modes.)

**I Logic 7 Mode Indicators:** These indicators light when the Logic 7 mode is in use. **LOGIC 7C** appears for the Cinema version of Logic 7; **LOGIC 7M** appears for the Music version of Logic 7. (See page 22 for a description of the Logic 7 modes.)

**J Preset Number/Sleep Timer:** When the tuner is in use, these numbers indicate the specific preset memory location in use. (See page 25 for more information on preset stations.) When the Sleep function is in use, these numbers show how many minutes remain before the unit goes into the Standby mode. (See page 21 for information on the Sleep Function.)

**K Night Mode Indicator:** This indicator lights when the AVR 125 is in the Night mode, which preserves the dynamic range of digital program material at low

volume levels. This mode is only available with specially encoded Dolby Digital sources. (See page 24 for a description of the Night Mode.)

**L Speaker/Channel Input Indicators:** These indicators are multipurpose, indicating either the speaker type selected for each channel or the incoming data-signal configuration. The left, center, right, right surround and left surround speaker indicators are composed of three boxes, while the subwoofer is a single box. The center box lights when a “small” speaker is selected, and the two outer boxes light when “large” speakers are selected. When none of the boxes are lit for the center, surround or subwoofer channels, no speaker has been assigned to one of those positions. (See page 17 for more information on configuring speakers.) The letters inside each of the center boxes display active input channels. For standard analog inputs, only the L and R will light, indicating a stereo input. When a digital source is playing, the indicators will light to display the channels being received at the digital input. When the letters flash, the digital input has been interrupted. (See pages 18–19 for more information on the Channel Indicators.)

**M Preset Indicator:** This indicator lights when the tuner is in use to show that the **Preset Number/Sleep Timer J** is showing the station’s preset memory number. (See page 25 for more information on tuner presets.)

**N Sleep Indicator:** This indicator lights when the Sleep function is in use. The numbers in the Preset Number/Sleep Timer Indicators will show the minutes

# FRONT - PANEL INFORMATION DISPLAY

remaining before the AVR 125 goes into the Standby mode. (See page 21 for more information.)

**M** **Memory Indicator:** This indicator flashes when entering presets and other information into the tuner's memory.

**P** **Stereo Indicator:** This indicator lights when an FM station is being tuned in stereo.

**T** **Tuned Indicator:** This indicator lights when a station is being received with sufficient signal strength to provide acceptable listening quality.

**A** **Auto Indicator:** This indicator lights when the tuner's Auto mode is in use.

**S** **Analog Input Indicator:** This indicator lights when an analog input source has been selected.

**D** **Coaxial Digital Input Indicators:** These indicators light to show when a Coaxial Digital Input has been selected.

**O** **Optical Digital Input Indicators:** These indicators light to show when an Optical Digital Input has been selected.

**NOTE:** See page 23 for information on assigning either an analog input or one of the digital inputs to the source currently in use.



# REAR-PANEL CONNECTIONS

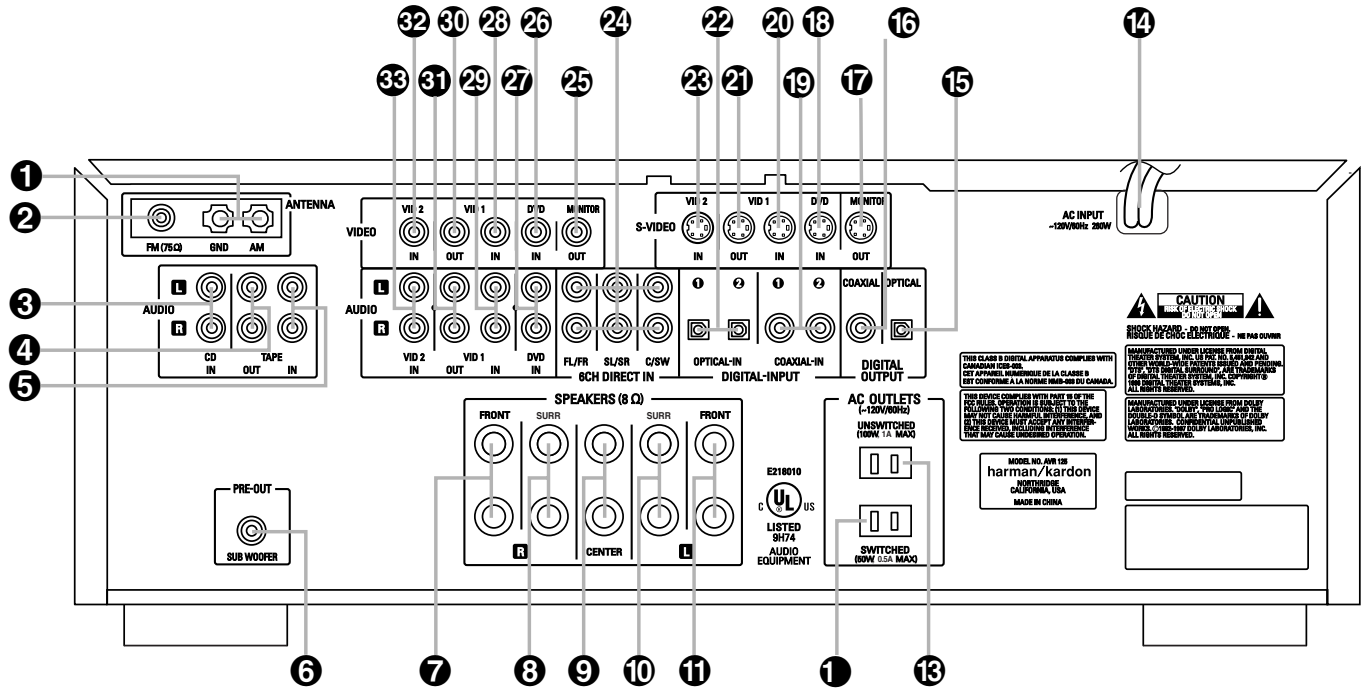

- 1 AM Antenna
- 2 FM Antenna
- 3 CD Inputs
- 4 Tape Outputs
- 5 Tape Inputs
- 6 Subwoofer Output
- 7 Front Speaker Outputs
- 8 Surround Speaker Outputs
- 9 Front Speaker Outputs
- 10 Surround Speaker Outputs
- 11 Front Speaker Outputs
- 1 Switched AC Accessory Outlet
- 13 Unswitched AC Accessory Outlet

- 14 AC Power Cord
- 15 Optical Digital Output
- 16 Coaxial Digital Output
- 17 Video Monitor S-Video Output
- 18 DVD S-Video Input
- 19 Coaxial Digital Inputs
- 20 Video 1 S-Video Input
- 21 Video 1 S-Video Output
- 22 Optical Digital Inputs
- 23 Video 2 S-Video Input
- 24 6-Channel Direct Inputs
- 25 Video Monitor Composite Video Output
- 26 DVD Composite Video Input

- 27 DVD Audio Inputs
- 28 Video 1 Composite Video Input
- 29 Video 1 Audio Inputs
- 30 Video 1 Composite Video Output
- 31 Video 1 Audio Outputs
- 32 Video 2 Composite Video Input
- 33 Video 2 Audio Inputs

**1 AM Antenna:** Connect the AM loop antenna supplied with the receiver to these terminals. If an external AM antenna is used, make connections to the **AM** and **GND** terminals in accordance with the instructions supplied with the antenna.

**2 FM Antenna:** Connect the supplied indoor or an optional external FM antenna to this terminal.

**3 CD Inputs:** Connect these jacks to the output of a compact disc player or CD changer.

**4 Tape Outputs:** Connect these jacks to the **RECORD/INPUT** jacks of an audio recorder.

**5 Tape Inputs:** Connect these jacks to the **PLAY/OUT** jacks of an audio recorder.

**6 Subwoofer Output:** Connect this jack to the line-level input of a powered subwoofer. If an external subwoofer amplifier is used, connect this jack to the subwoofer amplifier input.

**7 9 11 Front Speaker Outputs:** Connect these outputs to the matching + or – terminals on your front speakers. When making speaker connections, always make certain to maintain correct polarity by connecting the black terminal to the negative (–) terminal on the speakers. Connect the white terminal to the positive (+) terminal on the left front speaker, the red terminal to the positive (+) terminal on the right front speaker and the green terminal to the positive (+) terminal on the center front speaker. Newer speakers may have matching color terminals in accordance with the new CEA specifications, while existing speakers typically use a red terminal for the positive (+) speaker wire

connection. (See page 14 for more information on speaker polarity.)

**8 10 Surround Speaker Outputs:** Connect these outputs to the matching + or – terminals on your left and right surround speakers. When making speaker connections always make certain to maintain correct polarity by connecting the black terminal to the negative (–) terminal on the speakers. Connect the blue terminal to the positive (+) terminal on the left surround speaker and the gray terminal to the positive (+) terminal on the right surround speaker. Newer speakers may have matching color terminals in accordance with the new CEA specifications, while existing speakers typically use a red terminal for the positive (+) speaker wire connection. (See page 14 for more information on speaker polarity.)

# REAR-PANEL CONNECTIONS

**1** **Switched AC Accessory Outlet:** This outlet may be used to power any device you wish to have turned on or off at the same time as the AVR 125. Any device connected to this outlet will be off when the AVR 125 is in the Standby mode, and power will be supplied to the outlet when the AVR 125 is turned on.

**13** **Unswitched AC Accessory Outlet:** This outlet may be used to power any AC device. The power will remain on at this outlet regardless of whether the AVR 125 is on or off.

**IMPORTANT NOTE:** The total power consumption of all devices connected to the accessory outlets should not exceed 100 watts. Do not connect power amplifiers or other high-current draw devices to these outlets.

**14** **AC Power Cord:** Connect the AC plug to an unswitched AC wall outlet.

**15** **Optical Digital Output:** Connect this jack to the matching digital audio input connector on a digital recorder such as a CD-R or MiniDisc recorder.

**16** **Coaxial Digital Output:** Connect this jack to the matching digital audio input connector on a digital recorder such as a CD-R or MiniDisc recorder.

**17** **25** **Video Monitor Outputs:** Connect these jacks to the composite or S-Video input of a TV monitor or video projector to view the output of any standard video source selected by the receiver's video switcher.

**18** **26** **DVD Video Inputs:** Connect one of these jacks to the composite or S-Video output jacks on a DVD or other video source.

**19** **Coaxial Digital Inputs:** Connect the coax digital audio output from a DVD player, HDTV receiver, LD player, satellite receiver, cable box, MiniDisc recorder or CD player to these jacks. The signal may be either a Dolby Digital signal, DTS signal or a standard PCM digital source. Do not connect the RF digital output of an LD player to these jacks.

**20** **23** **Video 1 Video Inputs:** Connect one of these jacks to the **PLAY/OUT** composite or S-Video jacks on a VCR or other video source.

**21** **30** **Video 1 Video Outputs:** Connect one of these jacks to the **RECORD/INPUT** composite or S-Video jack on a VCR.

**22** **Optical Digital Inputs:** Connect the optical digital audio output from a DVD player, HDTV receiver, LD player, satellite receiver, cable box, MiniDisc player or recorder, or CD player to these jacks. The signal may be either a Dolby Digital signal, a DTS signal or a standard PCM digital source.

**23** **32** **Video 2 Video Inputs:** Connect one of these jacks to the **PLAY/OUT** composite or S-Video jacks on a TV, VCR or other video source.

**24** **6-Channel Direct Inputs:** If an external digital audio decoder is used, connect the outputs of that decoder to these jacks.

These jacks have been color-coded as follows to assist you in making correct channel connections:

Front Left	White
Front Right	Red
Center	Green
Surround Left	Blue
Surround Right	Gray
Subwoofer	Purple

**27** **DVD Audio Inputs:** Connect these jacks to the analog audio jacks on a DVD player or other source device.

**NOTE:** The default setting for the audio input associated with DVD is the **Coaxial Digital Input 1** **19**. If you connect the audio outputs of a DVD player to the analog jacks **27**, change the input setting as shown on page 20.

**29** **Video 1 Audio Inputs:** Connect these jacks to the **PLAY/OUT** audio jacks on a VCR or other video source.

**31** **Video 1 Audio Outputs:** Connect these jacks to the **RECORD/INPUT** audio jacks on a VCR.

**33** **Video 2 Audio Inputs:** Connect these jacks to the **PLAY/OUT** audio jacks on a VCR, satellite receiver, cable box, video game or other composite video source.

# REMOTE CONTROL FUNCTIONS

- 1 Power Off Button
- 2 IR Transmitter Window
- 3 Program Indicator
- 4 Power On Button
- 5 Input Selectors
- 6 AVR Selector
- 7 AM/FM Tuner Select
- 8 Test Button
- 9 Sleep Button
- 10 Surround Mode Selector
- 11 Night Mode
- 12 Channel Select Button
- 13 ▲ Button
- 14 ◀ Button
- 15 Set Button
- 16 Digital Select
- 17 ▼ Button
- 18 Numeric Keys
- 19 Tuner Mode
- 20 Direct Button
- 21 Tuning Up/Down
- 22 Macro Buttons
- 23 Transport Controls
- 24 Skip Up/Down Buttons
- 25 Disc Skip Button
- 26 Preset Up/Down
- 27 Clear Button
- 28 Memory Button
- 29 Delay/Prev. Ch.
- 30 ▶ Button
- 31 Speaker Select
- 32 Spare Button
- 33 Volume Up/Down
- 34 TV/Video Selector
- 35 6-Channel Direct Input
- 36 Mute

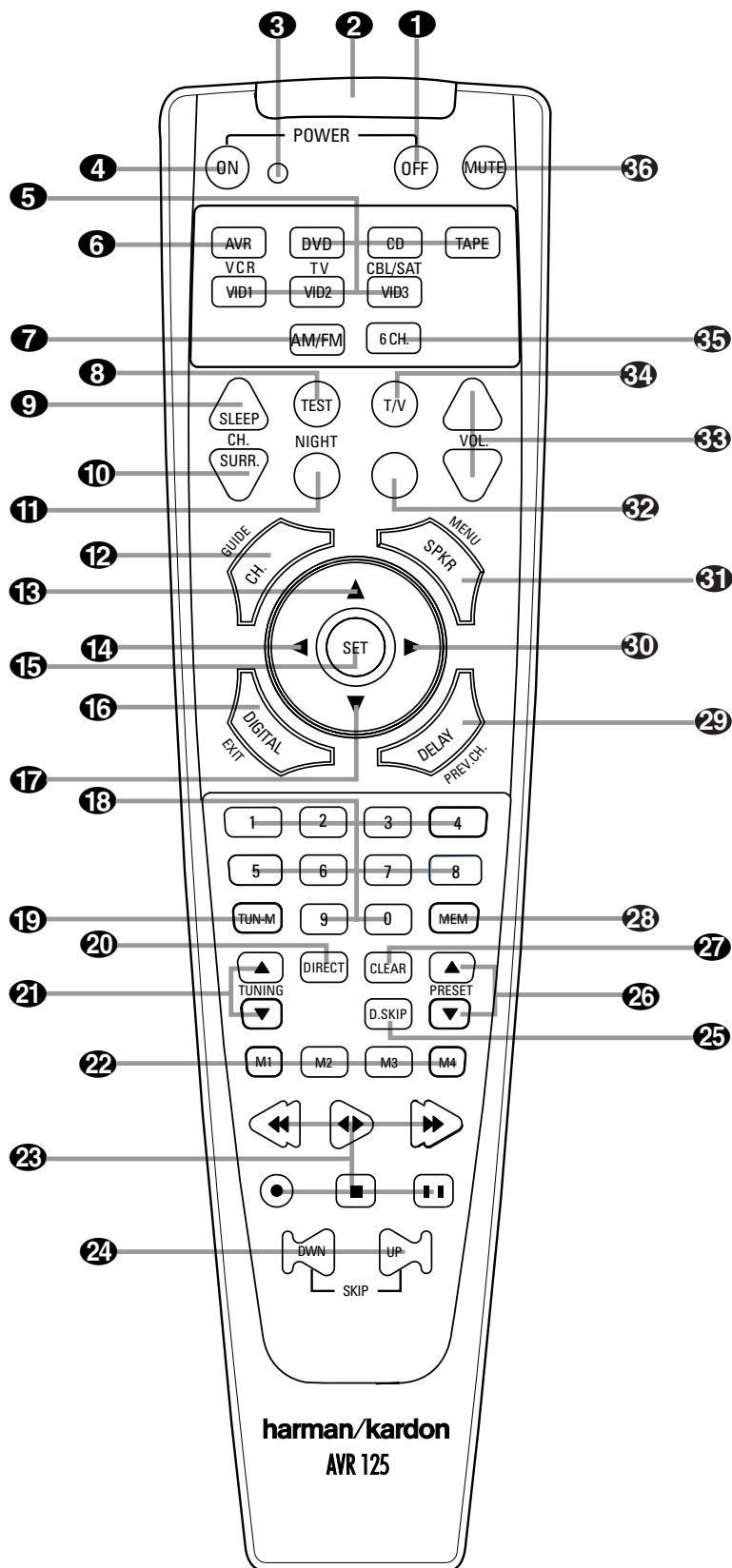

**NOTE:** The function names shown here refer to each button's feature when used with the AVR 125. Most buttons have additional functions when used with other devices. See pages 31–32 for a list of these functions.

# REMOTE CONTROL FUNCTIONS

**IMPORTANT NOTE:** The AVR 125's remote may be programmed to control up to seven devices, including the AVR 125. Before using the remote, remember to press the **Input Selector Button 5** that corresponds to the unit you wish to operate. In addition, the AVR 125's remote is shipped from the factory to operate the AVR 125 and most recent Harman Kardon products. The remote is also capable of operating a wide variety of other products using the control codes that are part of the remote. Before using the remote with other products, follow the instructions on pages 27–30 to program the proper codes for the products in your system.

It is also important to remember that many of the buttons on the remote take on different functions, depending on the product selected using the Device Control Selectors. The descriptions shown here primarily detail the functions of the remote when it is used to operate the AVR 125. (See pages 31–32 for information about alternate functions for the remote's buttons.)

**1 Power Off Button:** Pressing this button turns off (places in the Standby mode) the device that was last selected by pressing one of the **Input Selectors 5**. To place the AVR 125 in the Standby mode, first press the **AVR Selector Button 6** and then press this button.

**2 IR Transmitter Window:** Point this window towards the AVR 125 when pressing buttons on the remote to make certain that infrared commands are properly received.

**3 Program Indicator:** This three-color indicator is used to guide you through the process of programming the remote. (See pages 27–30 for information on programming the remote.)

**4 Power On Button:** After selecting a device by pressing one of the **Input Selectors 5**, press this button to turn the device on. To turn on the AVR 125, press the **AVR Selector Button 6**.

**5 Input Selectors:** Pressing one of these buttons will perform three actions at the same time. First, if the AVR 125 is not turned on, this will power up the unit. Next, it will select the source shown on the button as the input to the AVR 125. Finally, it will change the remote control so that it controls the device selected. After pressing one of these buttons you must press the **AVR Selector Button 6** again to operate the AVR 125's functions with the remote.

**6 AVR Selector:** Pressing this button will switch the remote so that it will operate the AVR 125's functions. If the AVR 125 is in the Standby mode, it will also turn the AVR 125 on.

**7 AM/FM Tuner Select:** Press this button to select the AVR 125's tuner as the listening choice. Pressing this button when the tuner is already in use will switch between the AM and FM bands.

**8 Test Button:** Press this button to begin the sequence used to calibrate the AVR 125's output levels. (See pages 18–19 for more information on calibrating the AVR 125.)

**9 Sleep Button:** Press this button to place the unit in the Sleep mode. After the time shown in the display, the AVR 125 will automatically go into the Standby mode. Each press of the button changes the time until turn-off in the following order:

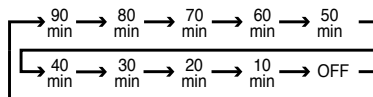

This button is also used to change channels on your TV when the TV is selected, and it is also used to end the process of creating a macro command. (See page 28 for more information on creating macros.)

**10 Surround Mode Selector:** Press this button to begin the process of changing the surround mode. After the button has been pressed, use the **▲/▼ Buttons 13 17** to select the desired surround mode. (See page 22 for more information.) This button is also used to tune channels when the TV is selected, and during the process of erasing stored macro commands. (See page 28 for more information on macros.)

**NOTE:** The **Sleep Button 9** and **Surround Mode Selector 10** may also function as the Channel + and – keys when the remote is programmed for use with TVs, cable boxes, VCRs, satellite receivers or other video devices with tuners. See page 29 for information on programming the remote for Channel Control Punch-Through capability so that you may change channels on a separate device when the remote is in AVR mode.

**11 Night Mode:** Press this button to activate the Night mode. This mode is available in specially encoded digital sources to preserve dialog (center channel) intelligibility at low volume levels.

**12 Channel Select Button:** This button is used to start the process of setting the AVR 125's output levels to an external source. Once this button is pressed, use the **▲/▼ Buttons 13 17** to select the channel being adjusted, then press the **Set Button 15**, followed by the **▲/▼ Buttons 13 17** again, to change the level setting. (See page 25 for more information.)

**13 ▲ Button:** This multipurpose button is used to change configuration settings such as output levels. When changing an item such as the surround mode or digital input directly, first press the function or mode to be changed (e.g., press the **Surround Mode Selector 10** to select a surround mode or the **Digital Select Button 16** to change the digital input) and then press this button to scroll through the list of available choices.

**14 ◀ Button:** This button is used to change the setting during some of the setup procedures for the AVR 125.

**15 Set Button:** This button is used to enter settings into the AVR 125's memory. It is also used in the setup procedures for delay time, speaker configuration and channel output level adjustment.

**16 Digital Select:** Press this button to assign one of the digital inputs **19 22 13 14** to the source currently in use. (See page 23 for more information on using digital inputs.)

**17 ▼ Button:** This multipurpose button is used to change configuration settings such as output levels. When changing an item such as the surround mode or digital input directly, first press the function or mode to be changed (e.g., press the **Surround Mode Selector 10** to select a surround mode or the **Digital Select Button 16** to change the digital input) and then press this button to scroll through the list of available choices.

**18 Numeric Keys:** These buttons serve as a ten-button numeric keypad to enter tuner preset positions. They are also used to select channel numbers when TV has been selected on the remote, or to select track numbers on a CD, DVD or LD player, depending on how the remote has been programmed.

**19 Tuner Mode:** Press this button when the tuner is in use to select between automatic tuning and manual tuning. In automatic tuning mode, the **AUTO Indicator R** will be lit, and only stations with acceptable signal quality may be tuned by pressing the **Tuning Up/Down Buttons 8 21**. When the button is pressed so that the **AUTO Indicator R** goes out, manual tuning mode is engaged, and pressing the **Tuning Buttons 21 8** will move the frequency up or down in single-step increments. When the FM band is in use, pressing this button when a station's signal is weak will change to monaural reception. (See page 25 for more information.)

**20 Direct Button:** When the tuner is in use, press this button to start the sequence for direct entry of a station's frequency. After pressing the button simply press the proper **Numeric Keys 18** to select a station. (See page 25 for more information on the tuner.)

## REMOTE CONTROL FUNCTIONS

**21 Tuning Up/Down:** When the tuner is in use, these buttons will tune up or down through the selected frequency band. If the **Tuner Mode Button 19 12** has been pressed so that the **AUTO Indicator R** is illuminated, pressing either of the buttons will cause the tuner to seek the next station with acceptable signal strength for quality reception. When the **AUTO Indicator R** is NOT illuminated, pressing these buttons will tune stations in single-step increments. (See page 25 for more information.)

**22 Macro Buttons:** Press these buttons to store or recall a "Macro", which is a preprogrammed sequence of commands stored in the remote. (See page 28 for more information on storing and recalling macros.)

**23 Transport Controls:** These buttons do not have any functions for the AVR 125, but they may be programmed for the forward/ reverse play operation of a wide variety of CD or DVD players, and audio or video cassette recorders. (See page 29 for more information on programming the Transport Control Punch-Through capability of the remote.)

**24 Skip Up/Down Button:** These buttons have no direct function with the AVR 125, but when used with a compatibly programmed CD or DVD changer, they will change the track or chapter of the disc currently being played in the changer.

**25 Disc Skip Button:** This button has no direct function for the AVR 125, but when used with a compatibly programmed CD or DVD changer, it will change the disc currently being played in the changer. (See page 28 for more information on using the remote with other devices.)

**26 Preset Up/Down:** When the tuner is in use, press these buttons to scroll through the stations programmed into the AVR 125's memory. When some source devices, such as CD players, VCRs and cassette decks, are selected using the device **Input Selectors 5**, these buttons may function as Chapter Step or Track Advance.

**27 Clear Button:** Press this button to clear incorrect entries when using the remote to directly enter a radio station's frequency.

**28 Memory Button:** Press this button to enter a radio station into the AVR 125's preset memory. Once the **Memory Indicator O** flashes, you have five seconds to enter a preset memory location using the **Numeric Keys 18**. (See page 25 for more information.)

**29 Delay/Prev Ch.:** Press this button to begin the process for setting the delay times used by the

AVR 125 when processing surround sound. After pressing this button, the delay times are entered by pressing the **Set Button 15** and then using the **▲/▼ Buttons 13 17** to change the setting. Press the **Set Button 15** again to complete the process. (See page 19 for more information.)

**30 ► Button:** Press this button to change a setting or selection when configuring many of the AVR 125's settings.

**31 Speaker Select:** Press this button to begin the process of configuring the AVR 125's bass management system for use with the type of speakers used in your system. Once the button has been pressed, use the **▲/▼ Buttons 13 17** to select the channel you wish to set up. Press the **Set Button 15** and then select another channel to configure. When all adjustments have been completed, press the **Set Button 15** twice to exit the settings and return to normal operation. (See page 17 for more information.)

**32 Spare Button:** This button does not have any function for the operation of the AVR 125, but it is available for use when programmed with the code from another remote. (See page 27 for information on programming the remote with codes for other devices.)

**33 Volume Up/Down:** Press these buttons to raise or lower the system volume. See page 29 for more information on programming the Volume Punch-Through capability of the remote, which allows you to change the AVR 125's volume while the remote is set to control another device.

**34 TV/Video Selector:** This button does not have a direct function on the AVR 125, but when used with a compatibly programmed VCR, DVD or satellite receiver that has a "TV/Video" function, pressing this button will switch between the output of the player or receiver and the external video input to that player. Consult the owner's manual for your specific player or receiver for the details of how it implements this function.

**35 6-Channel Direct Input:** Press this button to select the component connected to the **6-Channel Direct Input 24** as the source.

**36 Mute:** Press this button to momentarily silence the AVR 125 or TV set being controlled, depending on which device has been selected. When the AVR 125 is muted, press this button or use the **Volume Control 20 33** to return to the previous volume level. When the AVR 125 remote is being programmed

to operate another device or when a macro command is being programmed, this button is pressed with the **Input Selector Button 5** to begin the programming process. (See page 27 for more information on programming the remote.)



# INSTALLATION AND CONNECTIONS

## System Installation

After unpacking the unit, and placing it on a solid surface capable of supporting its weight, you will need to make the connections to your audio and video equipment.

## Audio Equipment Connections

We recommend that you use high-quality interconnect cables when making connections to source equipment and recorders to preserve the integrity of the signals.

When making connections to audio source equipment or speakers it is always a good practice to unplug the unit from the AC wall outlet. This prevents any possibility of accidentally sending audio or transient signals to the speakers that may damage them.

1. Connect the analog output of a CD player to the **CD Inputs 3**.

**NOTE:** When the CD player has both fixed and variable audio outputs it is best to use the fixed output unless you find that the input to the receiver is so low that the sound is noisy, or so high that the signal is distorted.

2. Connect the analog Play/Out jacks of a cassette deck, MD, CD-R or other audio recorder to the **Tape Input Jacks 5**. Connect the analog Record/In jacks on the recorder to the **Tape Output Jacks 4** on the AVR 125.

3. Connect the output of any digital sources to the appropriate input connections on the AVR 125 rear panel. Note that the **Optical and Coaxial Digital Inputs 19 22 13 14** may be used with a Dolby Digital or DTS source such as a DVD player, or the output of a conventional CD or LD player's PCM (S/P-DIF) output.

4. Connect the **Optical Digital Output 15** or **Coaxial Digital Output 16** on the rear panel of the AVR 125 to the matching digital input connections on a CD-R or MiniDisc recorder.

5. Assemble the AM Loop Antenna supplied with the unit as shown below. Connect it to the **AM and GND Screw Terminals 1**.

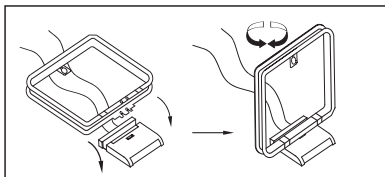

6. Connect the supplied FM antenna to the **FM Antenna (75 ohm) Connection 2**. The FM antenna may also be an external roof antenna, an inside powered or wire lead antenna or a connection from a

cable TV system. Note that if the antenna or connection uses 300-ohm twin-lead cable, you must use the 300-ohm-to-75-ohm adapter supplied with the unit to make the connection.

7. If you have a DVD-Audio or SACD player, or other component that includes an onboard surround decoder and 6-channel line-level audio outputs, you may connect these audio outputs to the **6-Channel Direct Inputs 24**. It is also necessary to connect the coax or optical digital output of a DVD player to coax or optical digital inputs on the AVR 125 **19 22 13 14** to take advantage of Dolby Digital or DTS soundtracks. Connect the DVD player's video outputs to the **DVD Video Input Jacks 18 25**. For audio-only sources, such as DVD audio or SACD, select the 6-Channel Direct Input source. For video sources, such as a DVD select the DVD Input.

8. Connect the front, center and surround **Speaker Outputs 7 8 9 10 11** to the respective speakers.

To ensure that all the audio signals are carried to your speakers without loss of clarity or resolution, we suggest that you use high-quality speaker cable. Many brands of cable are available and the choice of cable may be influenced by the distance between your speakers and the receiver, the type of speakers you use, personal preferences and other factors. Your dealer or installer is a valuable resource to consult in selecting the proper cable.

Regardless of the brand of cable selected, we recommend that you use a cable constructed of fine, multi-strand copper with a gauge of 14 or smaller. Remember that in specifying cable, the lower the number, the thicker the cable.

Cable with a gauge of 16 may be used for short runs of less than ten feet. We do not recommend that you use cables with an AWG equivalent of 18 or higher due to the power loss and degradation in performance that will occur.

Cables that are run inside walls should have the appropriate markings to indicate listing with UL, CSA or other appropriate testing agency standards. Questions about running cables inside walls should be referred to your installer or a licensed electrical contractor who is familiar with the NEC and/or the applicable local building codes in your area.

When connecting wires to the speakers, be certain to observe proper polarity. Remember to connect the "negative" or "black" wire to the same terminal on both the receiver and the speaker. The AVR 125 conforms to the latest CEA-recommended color-coding for speaker terminals. Accordingly, the positive (+) terminal, which was previously red, is now a specific

color to assist you in making the correct connections. If your speakers have color-coded connections, match the terminal on the AVR 125 to the like terminal on your speakers. For existing speakers with a red terminal for the positive connection, the connections on the AVR 125 are as follows:

Front Left = White	Front Right = Red
Center = Green	
Surround Left = Blue	Surround Right = Gray

While most speaker manufacturers adhere to an industry convention of using black terminals for negative and red ones for positive, some manufacturers may vary from this configuration. To ensure proper phase and optimal performance, consult the identification plate on your speaker or the speaker's manual to verify polarity. If you do not know the polarity of your speaker, ask your dealer for advice before proceeding, or consult the speaker's manufacturer.

We also recommend that the length of cable used to connect speaker pairs be identical. For example, use the same length piece of cable to connect the front-left and front-right or surround-left and surround-right speakers, even if the speakers are a different distance from the AVR 125.

9. Connections to a subwoofer are normally made via a line-level audio connection from the **Subwoofer Output 6** to the line-level input of a subwoofer with a built-in amplifier. When a passive subwoofer is used, the connection first goes to a power amplifier, which will be connected to one or more subwoofer speakers. If you are using a powered subwoofer that does not have line-level input connections, follow the instructions furnished with the speaker for connection information.

## Video Equipment Connections

Video equipment is connected in the same manner as audio components. Again, the use of high-quality interconnect cables is recommended to preserve signal quality.

Although any compatible video device may be connected to any video input (with the exception of the **Video 1 Output Jacks 21 30 31**, which may only be connected to a video recorder), to make programming device codes into the remote control easier, we recommend that you connect your VCR to the **Video 1 Connectors 20 21 23 29 30 31**, your television to the **Video 2 Connectors 23 32 33**, and your cable-TV converter or satellite receiver to the **Video 3 Connectors 15 16**.

1. Connect a VCR's audio and video Play/Out jacks to the **Video 1 Input Jacks 20 23 29** on the rear panel. The Audio and Video Record/In jacks on the VCR

# INSTALLATION AND CONNECTIONS

should be connected to the **Video 1 Out Jacks** **21****30****31** on the AVR 125.

2. Connect the analog audio and video outputs of a television set or any other video source to the **Video 2 Jacks** **26****32****33**.

3. Connect the analog audio and video outputs of a cable TV converter or satellite receiver, or any other video source, to the **Video 3 Jacks** **15****16** on the front panel of the AVR 125.

4. Connect the analog audio and video outputs of a DVD or laser disc player to the **DVD Jacks** **18****26****27**. When a digital audio connection is used for your DVD player, the default connection is the **Coaxial Digital Input 1 Jack** **19**. However, the connection may also be made to any of the **Optical** **22****13** or **Coaxial** **19****14** **Digital Inputs**, provided that the digital input source selection is changed as shown on page 23. If your DVD or DVD-Audio player includes an onboard surround decoder and 6-channel line-level audio outputs, you may connect these audio outputs to the **6-Channel Direct Inputs** **24**. When you wish to hear this decoded audio, select the DVD Input first in order to select the video signal from the DVD player, then select the 6-Channel Direct Input source for the audio.

5. Connect the digital audio outputs of a DVD player, satellite receiver, cable box or HDTV converter to the appropriate **Optical** or **Coaxial Digital Inputs** **19****22****13****14**.

6. Connect the **Video Monitor Output** **17****25** jacks on the receiver to the composite or S-Video input of your television monitor or video projector.

#### VIDEO CONNECTION NOTE:

- Composite and S-Video signals may only be viewed in their native formats. The AVR 125 will not convert signals from composite to S-Video, or vice versa. S-Video inputs may only be viewed when the AVR 125 is connected to a TV set or video display with S-Video capability. If you use both standard composite video and S-Video sources in your system, it is important that you connect both an S-Video cable and a standard composite video cable (a coax cable with an RCA plug on both ends) between the AVR 125 and your TV or projector. When it is necessary to make both types of connections to your TV set, use different inputs if possible. Consult the instructions for your TV set or projector for more information on connecting both types of signals.

#### Power Connections

This unit is equipped with two accessory AC outlets. They may be used to power accessory devices, but they should not be used with high-current draw equipment such as power amplifiers. The total power draw to each outlet may not exceed 100 watts.

The **Switched AC Accessory Outlet** **1** will receive power only when the unit is on. This is recommended for devices that have no power switch or a mechanical power switch that may be left in the "ON" position.

**NOTE:** Many audio and video products go into a Standby mode when they are used with switched outlets, and cannot be fully turned on using the outlet alone without a remote control command.

The **Unswitched AC Accessory Outlet** **13** will receive power as long as the unit is plugged into a powered AC outlet.

Finally, when all connections are complete, plug the **Power Cord** **14** into a nonswitched 120-volt AC wall outlet. You're almost ready to enjoy the AVR 125!



# TROUBLESHOOTING GUIDE

Your AVR 125 receiver has been designed to provide many years of trouble-free service. In the event that you are experiencing difficulties, please check the suggestions below for a possible solution to your problem. Additional information on the AVR 125, including updated information and user hints, is available from our Web site at [www.harmankardon.com](http://www.harmankardon.com).

SYMPTOM	CAUSE	SOLUTION
Unit does not function when Main Power Switch is pushed	<ul style="list-style-type: none"> <li>No AC Power</li> </ul>	<ul style="list-style-type: none"> <li>Make certain AC power cord is plugged into a live outlet</li> <li>Check to see whether outlet is switch-controlled</li> </ul>
Display lights, but no sound or picture	<ul style="list-style-type: none"> <li>Intermittent input connections</li> <li><b>Mute</b> is on</li> <li>Volume control is down</li> </ul>	<ul style="list-style-type: none"> <li>Make certain that all input and speaker connections are secure</li> <li>Press <b>Mute</b> button</li> <li>Turn up volume control</li> </ul>
Unit turns on, but front-panel display does not light up	<ul style="list-style-type: none"> <li>Display brightness is turned off</li> </ul>	<ul style="list-style-type: none"> <li>Follow the instructions in the Display Brightness section on page 26 so that the display is set to <b>VFD FULL</b></li> </ul>
No sound from any speaker; light around power switch is red	<ul style="list-style-type: none"> <li>Amplifier is in protection mode due to possible short</li> <li>Amplifier is in protection mode due to internal problems</li> </ul>	<ul style="list-style-type: none"> <li>Check speaker wire connections for shorts at receiver and speaker ends</li> <li>Contact your local Harman Kardon service center, which you can locate by visiting our Web site at <a href="http://www.harmankardon.com">www.harmankardon.com</a></li> </ul>
No sound from surround or center speakers	<ul style="list-style-type: none"> <li>Incorrect surround mode</li> <li>Input is monaural</li> <li>Incorrect configuration</li> <li>Stereo or Mono program material</li> </ul>	<ul style="list-style-type: none"> <li>Select a mode other than Stereo or Dolby 3 Stereo</li> <li>There is no surround information from mono sources</li> <li>Check speaker mode configuration</li> <li>The surround decoder may not create center- or rear-channel information from nonencoded programs</li> </ul>
Unit does not respond to remote commands	<ul style="list-style-type: none"> <li>Weak batteries in remote</li> <li>Wrong device selected</li> <li>Remote sensor is obscured</li> </ul>	<ul style="list-style-type: none"> <li>Change remote batteries</li> <li>Press the AVR selector</li> <li>Make certain front-panel sensor is visible to remote or connect remote sensor</li> </ul>
Intermittent buzzing in tuner	<ul style="list-style-type: none"> <li>Local interference</li> </ul>	<ul style="list-style-type: none"> <li>Move unit or antenna away from computers, fluorescent lights, motors or other electrical appliances</li> </ul>
Letters flash in the channel indicator display and digital audio stops	<ul style="list-style-type: none"> <li>Digital audio feed paused</li> </ul>	<ul style="list-style-type: none"> <li>Resume play for DVD</li> <li>Check that Digital Input is selected</li> </ul>

## Processor Reset

In the rare case where the unit's operation or the displays seem abnormal, the cause may involve the erratic operation of the system's memory or micro-processor.

To correct this problem, first unplug the unit from the AC wall outlet and wait at least three minutes. After the pause, reconnect the AC power cord and check the unit's operation. If the system still malfunctions, a system "reset" may clear the problem.

To clear the AVR 125's entire system memory including tuner presets, output level settings, delay times and speaker configuration data, first put the unit in Standby by pressing the **System Power Control Button 2**.

Next, press and hold the **Tone Mode 6** button for three seconds.

The unit will turn on automatically and display the **RESET** message in the **Main Information Display F**. Note that once you have cleared the memory in this manner, it is necessary to reestablish all system configuration settings and tuner presets.

The reset will not affect settings that were programmed into the remote control. To reset the remote control and restore it to its factory default settings, please follow the instructions on page 29.

If these steps do not solve the problem, consult an authorized Harman Kardon service center. You can locate the service center nearest to you by visiting our Web site at [www.harmankardon.com](http://www.harmankardon.com).

## Memory Backup

This product is equipped with a memory backup system that preserves the system configuration information and tuner presets if the unit is accidentally unplugged or subjected to a power outage. This memory will last for approximately one week, after which time all information must be reentered.

# AVR125 Exploded View

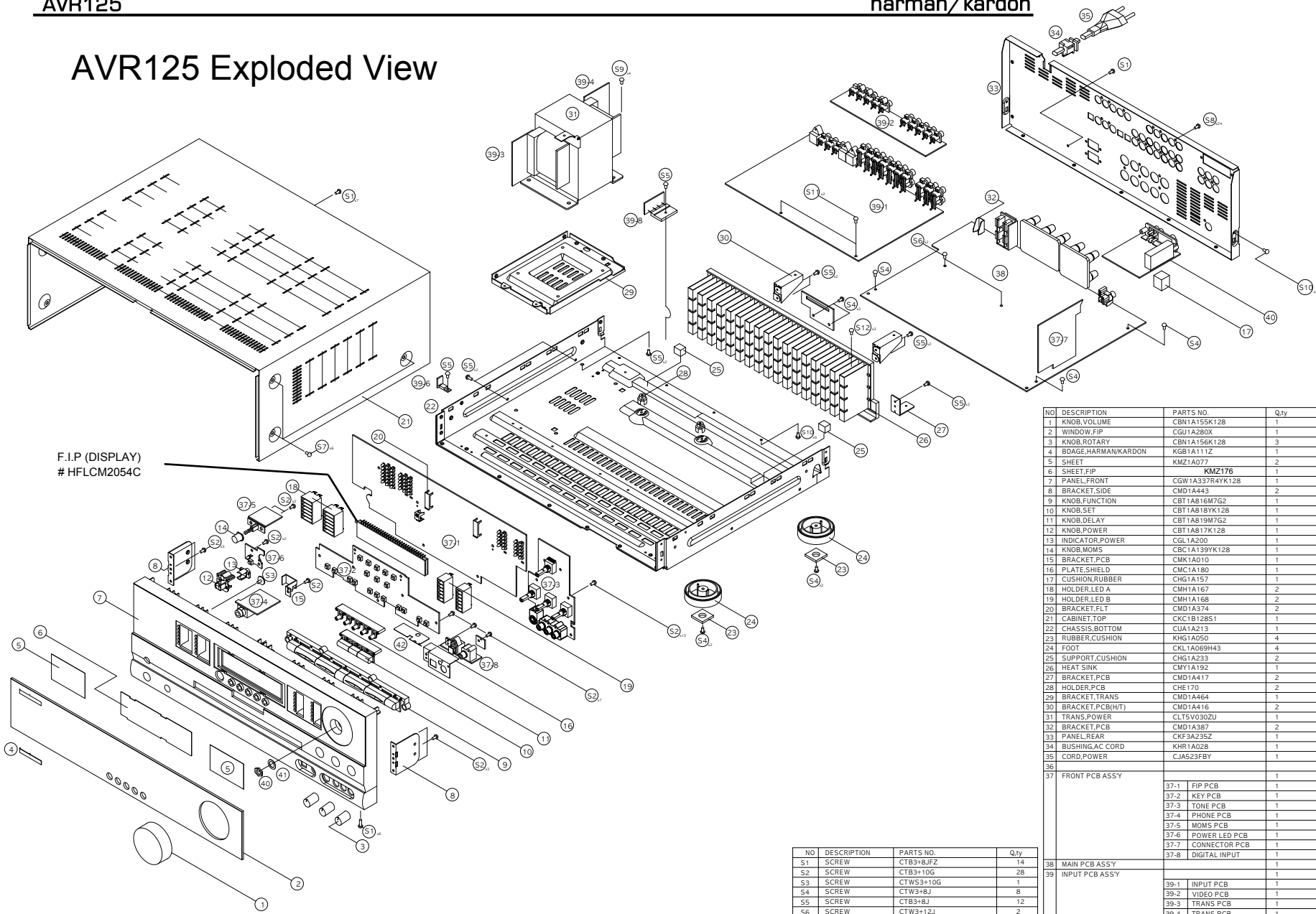

F.I.P (DISPLAY)  
# HFLCM2054C

NO	DESCRIPTION	PARTS NO.	Qty
51	SCREW	CTB3+8JFZ	14
52	SCREW	CTB3+10G	28
53	SCREW	CTW53+10G	1
54	SCREW	CTW3+8J	8
55	SCREW	CTB3+8J	12
56	SCREW	CTW3+12J	2
57	SCREW	CTB4+6FFZ	6
58	SCREW	CTB3+10GFZ	24
59	SCREW, TRANS	CHD1A023	4
S10	SCREW	CTB3+6J	7
S11	SCREW, SPECIAL	CHD1A012Z	2
S12	SCREW, SPECIAL	CHD2A012	4

NO	DESCRIPTION	PARTS NO.	Qty
1	KNOB, VOLUME	CBN1A155K128	1
2	WINDOW, FIP	CGU1A280X	1
3	KNOB, ROTARY	CBN1A156K128	3
4	BDAGE, HARMAN/KARDON	KGB1A111Z	1
5	SHEET	KMZ1A077	2
6	SHEET, FIP	KMZ176	1
7	PANEL, FRONT	CGW1A337R4YK128	1
8	BRACKET, SIDE	CMD1A443	2
9	KNOB, FUNCTION	CBT1A816M7G2	1
10	KNOB, SET	CBT1A818YK128	1
11	KNOB, DELAY	CBT1A819M7G2	1
12	KNOB, POWER	CBT1A817K128	1
13	INDICATOR, POWER	CGL1A200	1
14	KNOB, MOMS	CBCT1A39YK128	1
15	BRACKET, PCB	CMK1A010	1
16	PLATE, SHIELD	CMC1A180	1
17	CUSHION, RUBBER	CHG1A157	1
18	HOLDER, LED A	CMH1A167	2
19	HOLDER, LED B	CMH1A168	2
20	BRACKET, FLT	CMD1A374	2
21	CABINET, TOP	CKC1B128S1	1
22	CHASSIS, BOTTOM	CUA1A213	1
23	RUBBER, CUSHION	KHG1A050	4
24	FOOT	CKL1A069H43	4
25	SUPPORT, CUSHION	CHG1A233	2
26	HEAT SINK	CMY1A192	1
27	BRACKET, PCB	CMD1A417	2
28	HOLDER, PCB	CHE170	2
29	BRACKET, TRANS	CMD1A464	1
30	BRACKET, PCB(HT)	CMD1A416	2
31	TRANS, POWER	CLTSV0302U	1
32	BRACKET, PCB	CMD1A387	2
33	PANEL, REAR	CKF1A235Z	1
34	BUSHING, AC CORD	KHR1A028	1
35	CORD, POWER	CJAS23FBY	1
36			
37	FRONT PCB ASSY		1
		37-1 FIP PCB	1
		37-2 KEY PCB	1
		37-3 TONE PCB	1
		37-4 PHONE PCB	1
		37-5 MOMS PCB	1
		37-6 POWER LED PCB	1
		37-7 CONNECTOR PCB	1
		37-8 DIGITAL INPUT	1
38	MAIN PCB ASSY		1
39	INPUT PCB ASSY		1
		39-1 INPUT PCB	1
		39-2 VIDEO PCB	1
		39-3 TRANS PCB	1
		39-4 TRANS PCB	1
		39-6 TR PCB	1
		39-8 BRIDGE DIODE	1
40	NUT		1
41	WASHER		1
42	PLATE, SHIELD A	CMC1A189	1

## **AVR125/225 DISASSEMBLY PROCEDURE**

### **<1> TOP-CABINET(21) REMOVAL**

1. Remove 13 screws(S1,S7) and then remove the Top-cabinet.

### **<2> FRONT PANEL ASS'Y REMOVAL**

1. Remove the Top-cabinet, referring to the previous step<1>.
2. Disconnect the connect (BN72-Card canle)) on the FP PCB(37-1) from connector(CN72) on the Input PCB(39-1)
3. Disconnect the lead wire(BN80-8P) on the FP PCB(37-1) from connector(CN80) on the Main PCB(38).
4. Disconnect the lead wire(BN16-8P,BN10-4P) on the Tone PCB(37-3) from connector(CN16,CN10) on the Connect PCB(37-7).
5. Disconnect the lead wire(BN41-6P) on the Tone PCB(37-3) from connector(CN41) on the Video PCB(39-2).
6. Disconnect the lead wire(BN18-5P) on the Digital input PCB(37-8) from connector(CN18) on the Input PCB(39-1).
7. Disconnect the lead wire(BN81-6P,BN83-2P) on the FP PCB(37-1) from connector(CN81.CN83) on the Trans PCB(39-3).
8. Disconnect the lead wire(BN88-2P) on the Main PCB(38) from connector(CN88) on the Moms PCB(37-5).
9. Remove 1 screw(S10) and then lead wire(JW82-2P) on the Phone PCB(37-4).
10. Remove 9 screws(S1) and then remove the Front Panel ASS'Y.

### **<3> TONE PCB(37-3) REMOVAL**

1. Remove the Top-cabinet, referring to the previous step<1>.
2. Remove the Front Panel ASS'Y, referring to the previous step<2>.
3. Pull out the Volume Knob ASS'Y & 3 Rotary Knobs(5).
4. Remove 1 Nut(40), 1 Washer(41)
5. Remove 7 screws(S2) and then remove the Tone PCB(37-3).
6. Disconnect the lead wire(BN84-5P,BN90-2P) One the Tone PCB(37-3) from connector(CN84,CN90) on the FP PCB(37-1)
7. Disconnect the lead wire (BN87-6P) One the Tone PCB(37-3) from connector(CN87) on the Phone PCB(37-4)

### **<4>PHONE PCB(37-4) REMOVAL**

1. Remove the Top-cabinet, referring to the previous step<1>.
2. Remove the Front Panel ASS'Y, referring to the previous step<2>.
3. Disconnect the lead wire (BN87-6P) One the Tone PCB(37-3) from connector(CN87) on the Phone PCB(37-4)
4. Remove 2 screws(S2,S3) and then remove the Phone PCB(37-4)

### **<5>POWER LED PCB(37-6) REMOVAL**

1. Remove the Top-cabinet, referring to the previous step<1>.
2. Remove the Front Panel ASS'Y, referring to the previous step<2>.
3. Remove 2 screws(S2) and then remove the Power led PCB(37-6).
4. Disconnect the lead wire(BN88-4P) from connector(CN88) on the FP PCB(37-1).

### **<6>FRONT PCB(37-1) REMOVAL**

1. Remove the Top-cabinet, referring to the previous step<1>.
2. Remove the Front Panel ASS'Y, referring to the previous step<2>.
3. Remove the Tone PCB(37-3), referring to the previous step<3>.
4. Remove the Phone PCB(37-4), referring to the previous step<4>.
5. Remove the Power led PCB(37-6), referring to the previous step<5>.
6. Remove 6 screws(S2) and then remove the Front PCB(37-1)

## &lt;7&gt;TUNER MODULE(40) REMOVAL

1. Remove the Top-cabinet, referring to the previous step<1>.
2. Disconnect the connector(CON1-Card cable) from connector(CN13) on the Input PCB ASS'Y(39-1).
3. Remove 2 screws(S8) and then remove the Tuner Module(40).

## &lt;8&gt;VIDEO PCB(39-2) REMOVAL

1. Remove the Top-cabinet, referring to the previous step<1>.
2. Disconnect the lead wire(BN41-6P) on the Tone PCB(37-3) from connector(CN41) on the Video PCB(39-2).
3. Disconnect the connector (CN15-Card cable) on the Input PCB(39-1) from lead wire(CN43) on the Video PCB(39-2).
4. Remove 6 screws(S8) and then remove the Video PCB(39-2).

## &lt;9&gt;INPUT PCB(39-1) REMOVAL

1. Remove the Top-cabinet, referring to the previous step<1>.
2. Remove the Connect PCB(37-7).
3. Disconnect the lead wire(BN18-5P) on the Digital input PCB(37-8) from connector(CN18) on the Input PCB(39-1).
4. Disconnect the connect (BN72-Card canle)) on the FP PCB(37-1) from connector(CN72) on the Input PCB(39-1)
5. Remove 13 screws(S8,S11) and then remove the Input PCB(39-1).

## &lt;10&gt;POWER TRANS(31) REMOVAL

1. Remove the Top-cabinet, referring to the previous step<1>.
2. Disconnect the connector (CN20,BN96) on the Trans PCB from lead wire(CN20-3P,BN96-6P) on the Main PCB(38).
3. Remove 1 screw(S5) and then remove the Tr PCB(39-6)
4. Remove 1 screw(S5) and then remove the Bridge Diode PCB(39-8)
3. Remove 4 Trans screws(S9) and then remove the Power Trans(31).

## &lt;11&gt;MAIN PCB ASS'Y(38) REMOVAL

1. Remove the Top-cabinet, referring to the previous step<1>.
2. Remove the Tuner module, referring to the previous step<7>.
3. Remove the Video PCB, referring to the previous step<8>.
4. Remove the Input PCB, referring to the previous step<9>.
5. Disconnect the lead wire(BN80-8P) on the FP PCB(37-1) from connector(CN80) on the Main PCB(38).
6. Disconnect the lead wire(BN88-2P) on the Main PCB(38) from connector(CN88) on the Moms PCB(37-5).
7. Disconnect the connector (CN20,BN96) on the Trans PCB from lead wire(CN20-3P,BN96-6P) on the Main PCB(38)..
8. Remove 11 screws(S1-1EA, S4-2EA, S6-2EA, S8-6EA) and then remove the Main PCB ASS'Y(38).

# DISASSEMBLY

1) REMOVAL OF TOP COVER

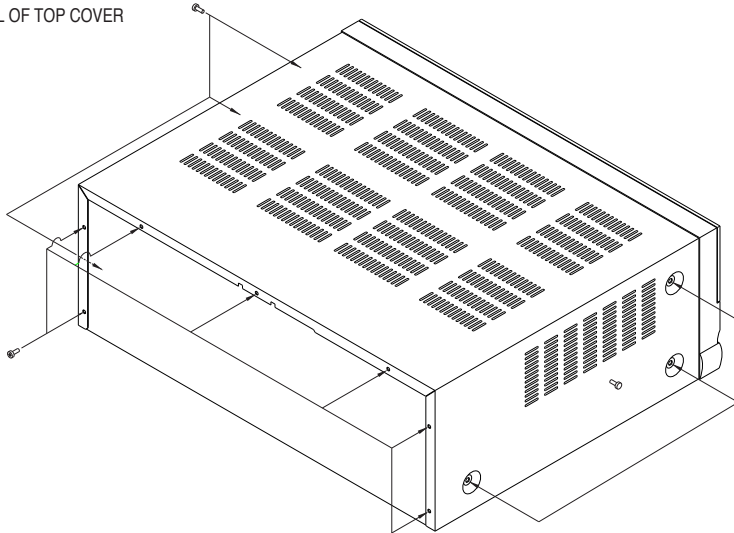

2) REMOVAL OF FRONT PANEL

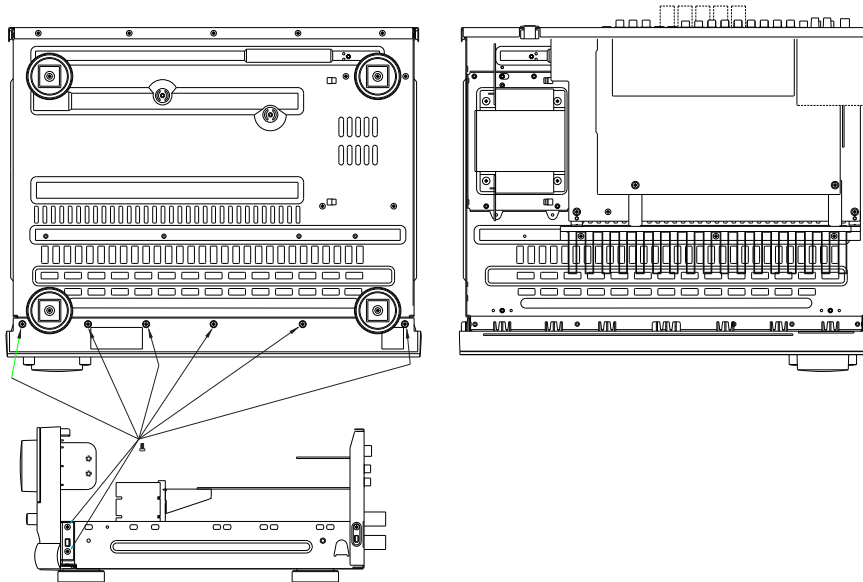

3) PRINCIPAL PARTS LOCATION

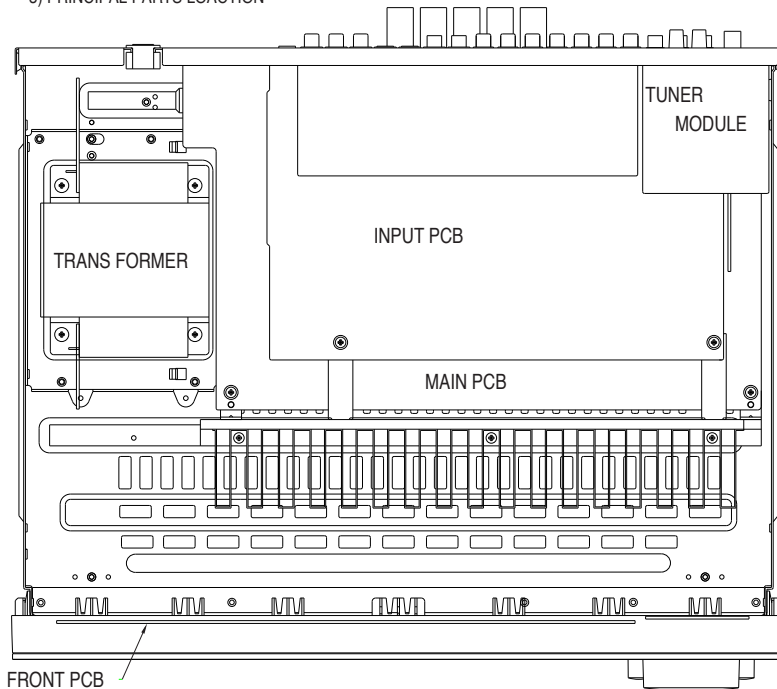

### AMPLIFIER SECTION BIAS ADJUSTMENT

**Measurement condition**

. No input signal or volume position is minimum.

**Standard value.**

. Ideal current = 48mA ( ± 5%)

. Ideal DC Voltage = 21.12mV ( ± 5%)

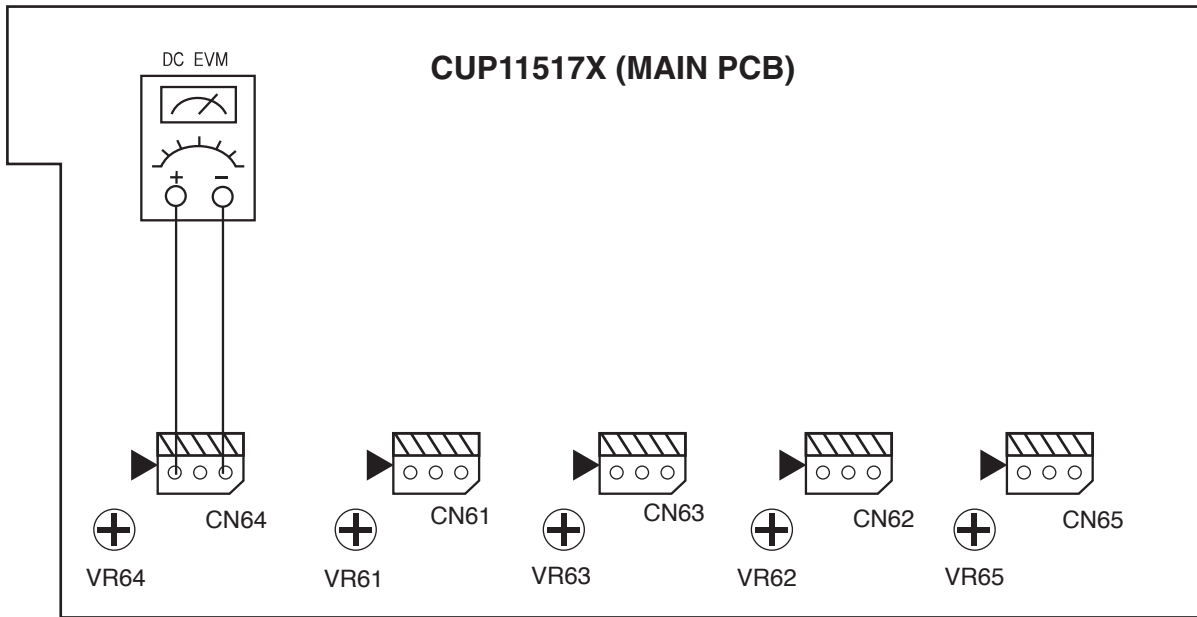

DC VOLTMETER.....Connect to CN61, CN62, CN63, CN64, CN65

NO.	Channel	Adjust for	Adjustment
1	Front Left	21.12mV (±5%)	VR61
2	Front Right	21.12mV (±5%)	VR62
3	Center	21.12mV (±5%)	VR63
4	Surround Left	21.12mV (±5%)	VR64
5	Surround Right	21.12mV (±5%)	VR65

**harman/kardon****TECH TIPS****Troubleshooting tips and solutions to common service problems**

For models:

TIP# HKTT2003-01 Rev5

AVR7000/7200/7300/8000	AVR10
AVR100/200/300/500	DPR1001
AVR110/210/310/510	DPR1005
AVR120/220/320/520	DPR2005
AVR125/225/325/525	HK3370/3470/3375/3475
AVR130/230/330/430/630	HK3250
AVR135/235/335/435/635	

**Subject:** Backup Memory on AVR/DPR/HK series receivers

**In the event of the complaint: “the receiver is losing its memory (any programmed system settings) when the unit is turned off, or after the unit is unplugged (briefly\*)”:**

Check and replace:

Model	Designator	Location	Description	Part number
AVR10	C712 D709	Front PCB	0.047 Farad 5.5v capacitor and 1N4148 diode	#3439247315 #2058322101
AVR7000	C730	Front PCB	0.047 Farad 5.5v capacitor	# P10790-ND or # J3432147324X
AVR7200	C106	Front PCB	0.047 Farad 5.5v capacitor	# P10790-ND
AVR7300	C657	DSP PCB	0.047 Farad 5.5v capacitor	# H01-CEZXA0479MN-5
AVR8000	C726	Front PCB	0.047 Farad 5.5v capacitor	# 55230310NR or # P10790-ND
AVR100/200	C412	Front PCB	0.047 Farad 5.5v capacitor	# CEGT-B473J-0J0
AVR300	C906	Front PCB	0.1Farad 5.5v capacitor	# J4433210421X or # P10791-ND
AVR500	C906	Front PCB	0.1Farad 5.5v capacitor	# J4433210421X or # P10791-ND
AVR110/210/310/510 AVR120/220/320/520	C216	Front PCB	0.047 Farad 5.5v capacitor	# P10790-ND
AVR125/225	C734,C885	Front PCB	two 0.1F capacitors in parallel	# BCESOHD104
AVR325/525	C106	Front PCB	0.047 Farad 5.5v capacitor	# P10790-ND
AVR130/230/330	BAT1	Front PCB	3.6v Battery	# HABGP40BVH3A3H
AVR135/235/335	BAT1	Front PCB	3.6v Battery	# HGP15BNH3A3H
AVR430/630	C657	DSP PCB	0.047 Farad 5.5v capacitor	# CEZXA0479MN-5
AVR435/635	C557	DSP PCB	0.047 Farad 5.5v capacitor	# H03-CEZXA0479MN-0
DPR1001	BC601	Main PCB	0.1Farad 5.5v capacitor	# CEGT-B104J-0J0
DPR1005/2005	C437	Processor PCB	0.047 Farad 5.5v capacitor	# CEZXA0479MN-5
HK3370/3470	C301	Front PCB	0.1Farad 5.5v capacitor	# CEGT-B104J-0J0
HK3375/3475	C301	Front PCB	0.1Farad 5.5v capacitor	# CEGT-B104J-0J0
HK3250	C712 D709	Front PCB	0.047 Farad 5.5v capacitor and 1N4148 diode	#3439247315 #2058322101

\* After approximately two weeks of being disconnected from AC supply, even a normally functioning receiver may lose any programmed settings and switch to default settings. (Four weeks for the DPR1005 & 2005)



**harman/kardon****TECH TIPS****Troubleshooting tips and solutions to common service problems****TIP# HKTT2004-03**

## Isolating audio problems in an AVR receiver Using 6/8 Direct In

The following charts are used to help the tech quickly isolate audio problems in an AVR receiver. Use the following procedures to help find what is working, then to quickly locate the problem area.

### Equipment needed:

- ✓ 1 set of (RCA) Y adaptors.
- ✓ Function/signal generator.
- ✓ Oscilloscope.

Models covered:	
AVR210	AVR310
AVR220	AVR320
AVR520	AVR225
AVR125	AVR525
AVR130	AVR230
AVR330	AVR430
AVR630	

### Procedure:

- 1) Do a factory reset of the receiver. (This will eliminate any common micro processor problems.) Reset List can be found in this service manual.
- 2) Print the block diagram from the service manual.
- 3) With no inputs or speakers attached to the AVR turn on the receiver and turn the volume all the way down.
- 4) Turn unit off.
- 5) Hook up an oscillator to the 6/8 Direct in jacks using the Y adaptors. Adjust the oscillator to about 0db (.775Volts RMS).
- 6) Hook up an oscilloscope to monitor the line out jacks. Or, if there are no line out (preamp out) jacks monitor the input to the power amps or the speaker outs. (AVR125, 225, 130 do not have preamp out jacks)
- 7) Turn the AVR on. Select 6 or 8 direct in, depending on the receiver.
- 8) Slowly turn the volume control up until you can easily measure the voltage at the line out jacks. ( -40 to -25db )

## Isolating audio problems in an AVR receiver Using 6/8 Direct In

- 9) At this point you will be able to check and assure all output levels are the same.
- 10) IF THE OUTPUT LEVELS ARE NOT THE SAME STOP! Go no further. At this point you will need to use the charts to see where you are losing your signal. The chart shows the analog signal flow from the input jacks to the output jacks.
- 11) If the output levels are the same check the power out stage at the speaker out jacks.
- 12) If you find the levels at the speaker out jacks are OK, your problem will be in the DSP part of the receiver.

Congratulations! You have now eliminated 90% of the electronics in the AVR and confirmed that the problem is in the DSP section.

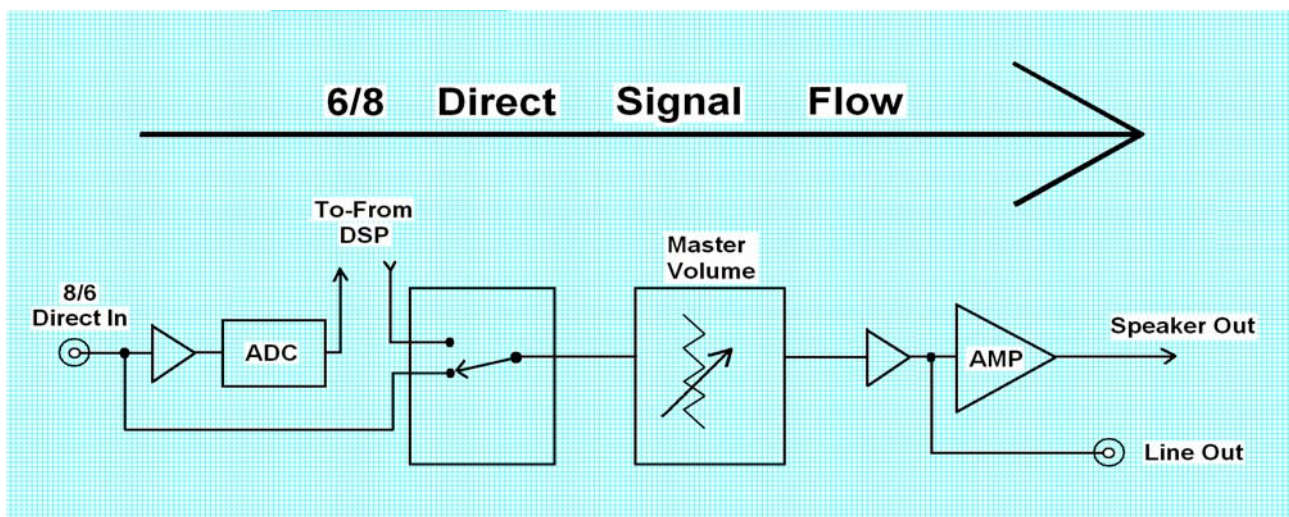

# Isolating audio problems in an AVR receiver Using 6/8 Direct In

### AVR,210,310,510

6 CH IN	IC 501 In	IC 501 Out	CN 408	IC 704 In	IC 704 Out	IC 705 In	IC 705 Out	IC 706 In	IC 706 Out	IC 705 In	IC 705 Out	IC 716 In	IC 716 Out	IC 717 In	IC 717 Out	IC 718 In	IC 718 Out	CP 405
FR	3	1	15	2	4	8	9	4	3	19	17	3	1					3
FL	5	7	13	27	25	21	20	25	26	10	12	5	7					1
SR			11	5	7		7	6					5	7				9
SL			9	24	22		22	23					3	1				7
C			5	21	19		19	20								3	1	5
SW			7	8	10		10	9							5	7	11	

### AVR220

6 CH IN	IC 501 In	IC 501 Out	CN 408	IC 704 In	IC 704 Out	IC 705 In	IC 705 Out	IC 706 In	IC 706 Out	IC 714 In	IC 714 Out	IC 705 In	IC 705 Out	IC 716 In	IC 716 Out	IC 717 In	IC 717 Out	IC 718 In	IC 718 Out	CP 405
FR	5	7	15	2	4	8	9	4	3	5	7	10	12	5	7					1
FL	3	1	13	27	25	21	20	25	26	3	1	19	17	3	1					3
SR			11	5	7		7	6								5	7			9
SL			9	24	22		22	23								3	1			7
C			5	21	19		19	20										3	1	5
SW			7	8	10		10	9										5	7	11

### AVR320/520

8 CH IN	IC 501 In	IC 501 Out	CN 408	IC 704 In	IC 704 Out	IC 705 In	IC 705 Out	IC 706 In	IC 706 Out	IC 714 In	IC 714 Out	IC 705 In	IC 705 Out	IC 716 In	IC 716 Out	IC 717 In	IC 717 Out	IC 718 In	IC 718 Out	CP 405
FR	5	7	15	2	4	8	9	4	3	5	7	10	12	5	7					1
FL	3	1	13	27	25	21	20	25	26	3	1	19	17	3	1					3
SR			11	5	7		7	6								5	7			9
SL			9	24	22		22	23								3	1			7
C			5	21	19		19	20										3	1	5
SW			7	8	10		10	9										5	7	11
			CN418	CP102	IC101 In	IC101 Out	IC102 In	IC102 oUT	ic103 in	ic103 Out										
SBR	3	3	3	4	21	23	5	7												
SBL	1	1	25	26	4	2	3	1												

### AVR225/125

6 CH IN	IC 30 In	IC 30 Out	IC 31 In	IC 31 Out	IC 32 In	IC 32 Out	IC 33 In	IC 33 Out	IC 34 In	IC 34 Out	BN12	IC 81 In	IC 81 Out	IC 80 In	IC 80 Out	BN16 In	BN16 Out
L ch	27	25	19	20	5	7					1	3	1	9	10	1	2
R ch	24	22	22	23	3	1					3	5	7	15	14	4	5
SL	5	4	7	6					5	7	9						
SR	2	4	10	9					3	1	11						
C	8	18	4	3			3	1			7						
SW	21	19	25	26			5	7			5						



# AVR125 BLOCK DIAGRAM

AVR125

harman/kardon

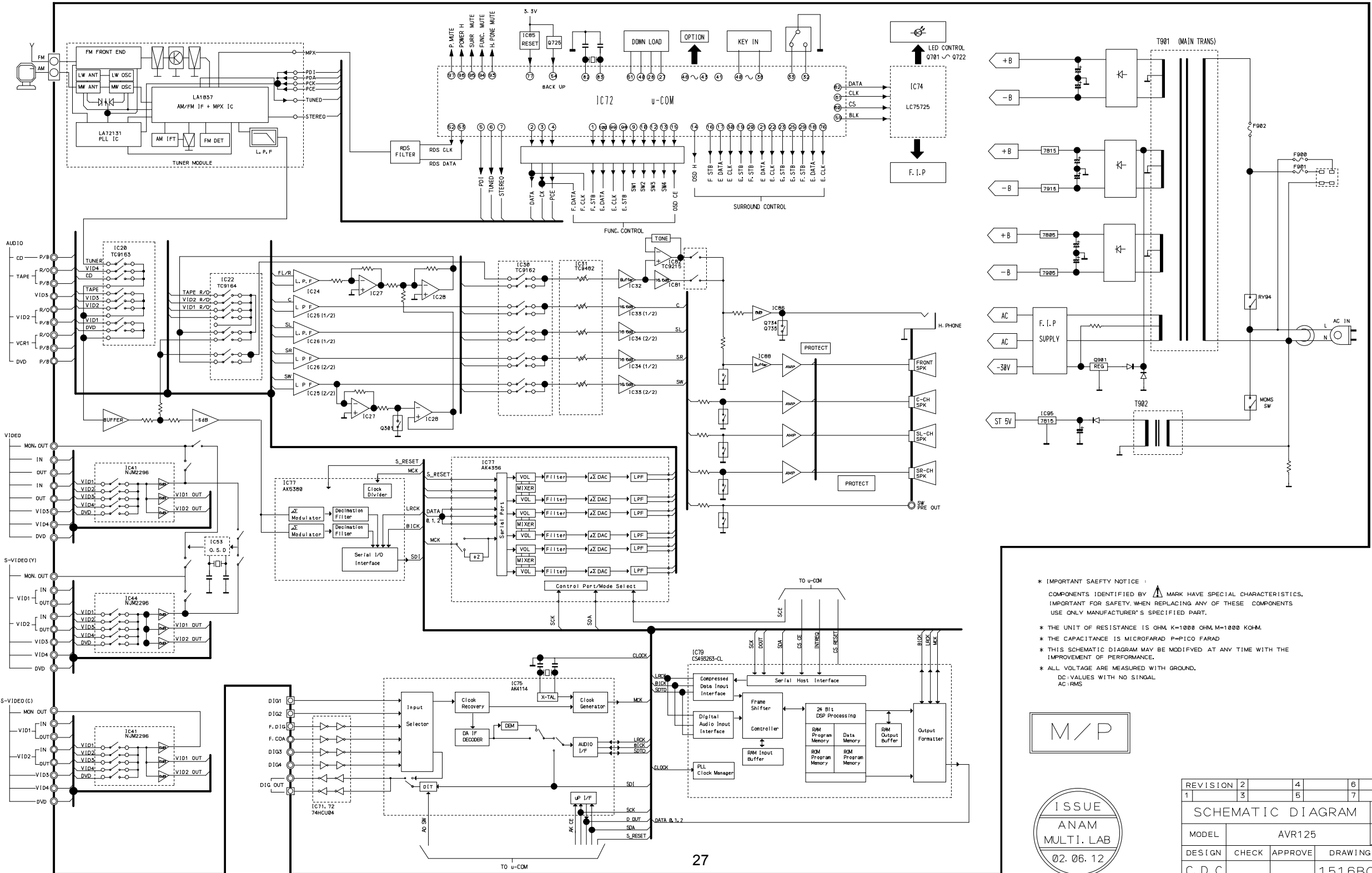

\* IMPORTANT SAFETY NOTICE :  
 COMPONENTS IDENTIFIED BY MARK HAVE SPECIAL CHARACTERISTICS. IMPORTANT FOR SAFETY, WHEN REPLACING ANY OF THESE COMPONENTS USE ONLY MANUFACTURER'S SPECIFIED PART.  
 \* THE UNIT OF RESISTANCE IS OHM, K=1000 OHM, M=1000 KOHM.  
 \* THE CAPACITANCE IS MICROFARAD P=PICO FARAD  
 \* THIS SCHEMATIC DIAGRAM MAY BE MODIFIED AT ANY TIME WITH THE IMPROVEMENT OF PERFORMANCE.  
 \* ALL VOLTAGE ARE MEASURED WITH GROUND.  
 DC: VALUES WITH NO SIGNAL  
 AC: RMS

M/P

ISSUE  
 ANAM  
 MULTI. LAB  
 02.06.12

REVISION	2	4	6
1	3	5	7
SCHEMATIC DIAGRAM			SHEET
MODEL	AVR125		1/1
DESIGN	CHECK	APPROVE	DRAWING NO
C. D. C			1516BCMZ
01.09.13			

**BLOCK DIAGRAM**

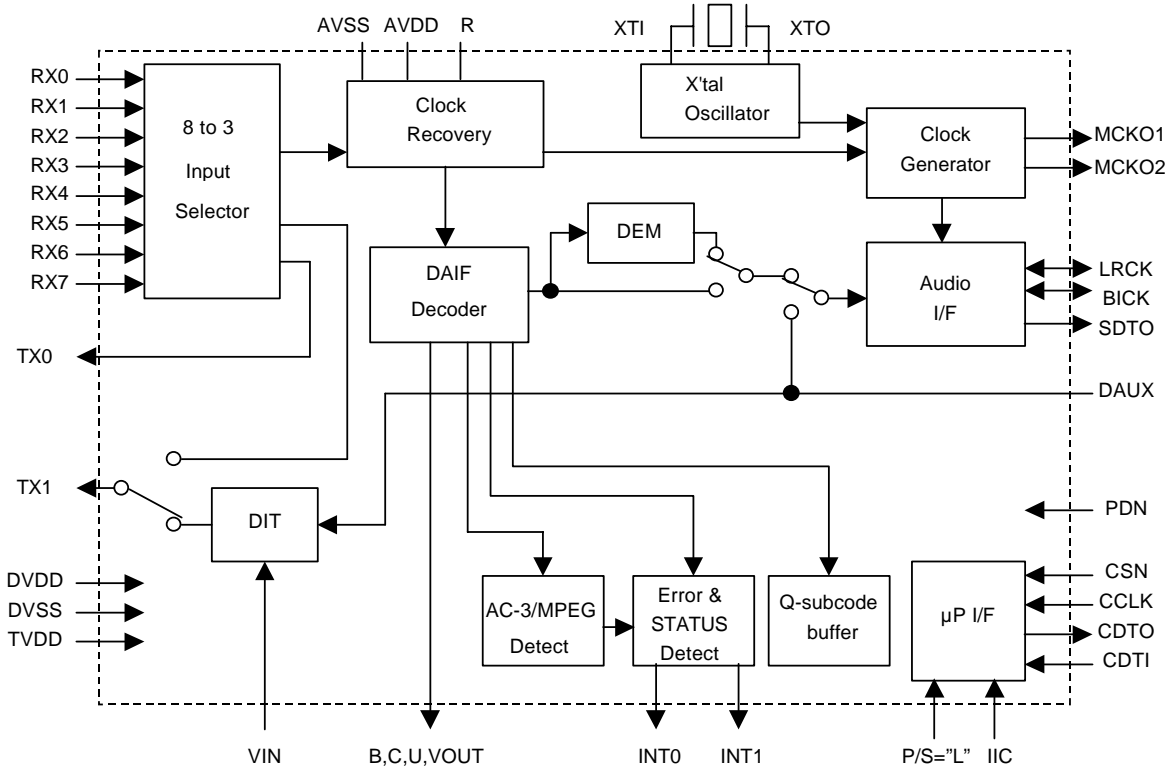

Serial Control Mode

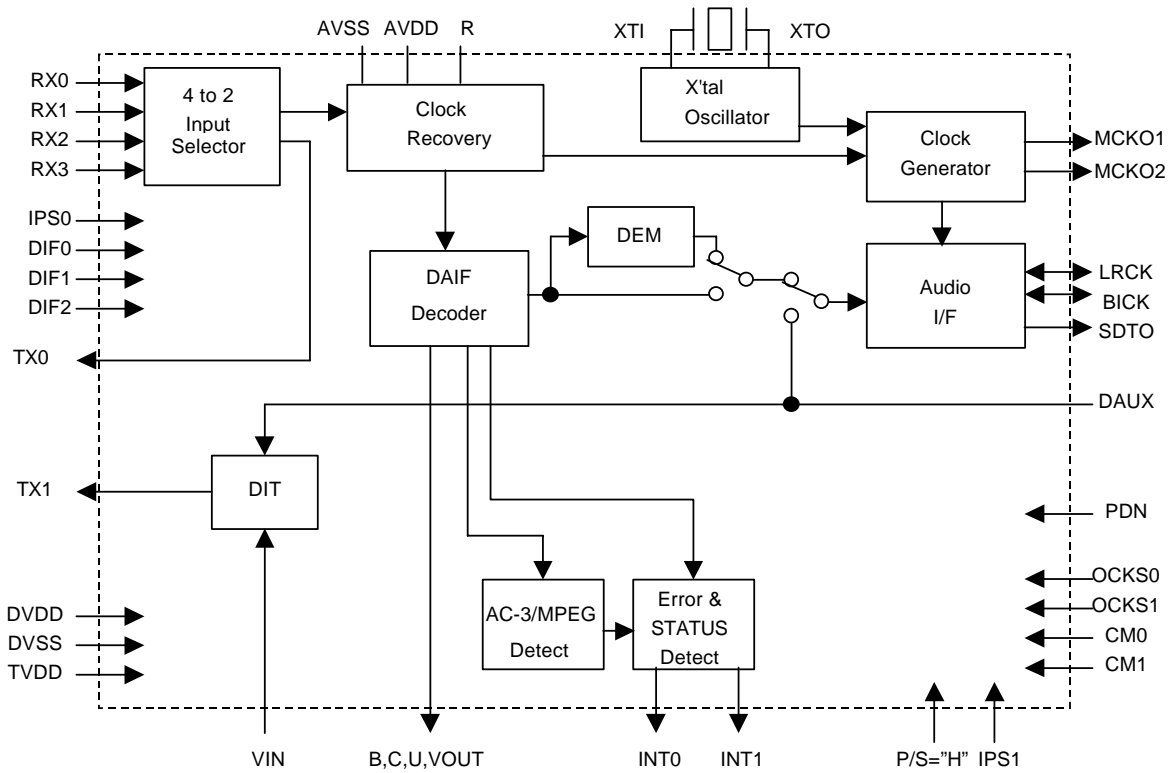

Parallel Control Mode

**DIR IC PIN ASSIGNMENT & BLOCK DIAGRAM**  
**PIN ASSIGNMENT (TOP VIEW)**

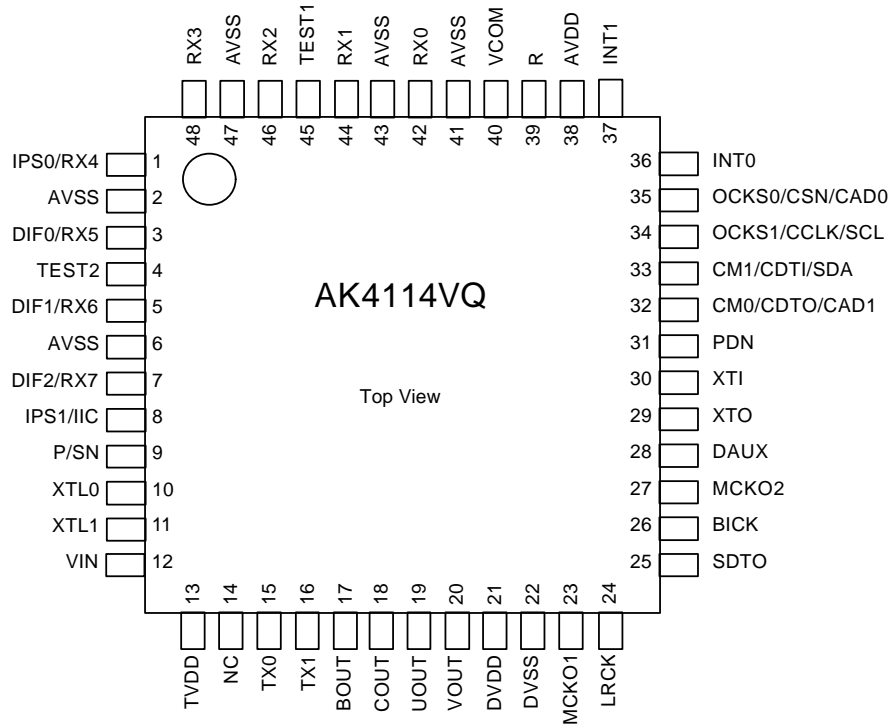



## IC PIN FUNCTION AK4114VQ IC75

PIN/FUNCTION			
No.	Pin Name	I/O	Function
1	IPS0	I	Input Channel Select 0 Pin in Parallel Mode
	RX4	I	Receiver Channel 4 Pin in Serial Mode (Internal biased pin)
2	NC(AVSS)	I	No Connect No internal bonding. This pin should be connected to AVSS.
3	DIF0	I	Audio Data Interface Format 0 Pin in Parallel Mode
	RX5	I	Receiver Channel 5 Pin in Serial Mode (Internal biased pin)
4	TEST2	I	TEST 2 pin This pin should be connect to AVSS.
5	DIF1	I	Audio Data Interface Format 1 Pin in Parallel Mode
	RX6	I	Receiver Channel 6 Pin in Serial Mode (Internal biased pin)
6	NC(AVSS)	I	No Connect No internal bonding. This pin should be connected to AVSS.
7	DIF2	I	Audio Data Interface Format 2 Pin in Parallel Mode
	RX7	I	Receiver Channel 7 Pin in Serial Mode (Internal biased pin)
8	IPS1	I	Input Channel Select 1 Pin in Parallel Mode
	IIC	I	IIC Select Pin in Serial Mode. “L”: 4-wire Serial, “H”: IIC
9	P/SN	I	Parallel/Serial Select Pin “L”: Serial Mode, “H”: Parallel Mode
10	XTL0	I	X'tal Frequency Select 0 Pin
11	XTL1	I	X'tal Frequency Select 1 Pin
12	VIN	I	V-bit Input Pin for Transmitter Output
13	TVDD	I	Input Buffer Power Supply Pin, 3.3V or 5V
14	NC	I	No Connect No internal bonding. This pin should be open or connected to DVSS.
15	TX0	O	Transmit Channel (Through Data) Output 0 Pin
16	TX1	O	When TX bit = “0”, Transmit Channel (Through Data) Output 1 Pin. When TX bit = “1”, Transmit Channel (DAUX Data) Output Pin (Default).
17	BOUT	O	Block-Start Output Pin for Receiver Input “H” during first 40 frames.
18	COUT	O	C-bit Output Pin for Receiver Input
19	UOUT	O	U-bit Output Pin for Receiver Input
20	VOUT	O	V-bit Output Pin for Receiver Input
21	DVDD	I	Digital Power Supply Pin, 3.3V
22	DVSS	I	Digital Ground Pin
23	MCKO1	O	Master Clock Output 1 Pin
24	LRCK	I/O	Channel Clock Pin
25	SDTO	O	Audio Serial Data Output Pin
26	BICK	I/O	Audio Serial Data Clock Pin
27	MCKO2	O	Master Clock Output 2 Pin
28	DAUX	I	Auxiliary Audio Data Input Pin
29	XTO	O	X'tal Output Pin
30	XTI	I	X'tal Input Pin

## PIN/FUNCTION (Continued)

No.	Pin Name	I/O	Function
31	PDN	I	Power-Down Mode Pin When "L", the AK4114 is powered-down and reset.
32	CM0	I	Master Clock Operation Mode 0 Pin in Parallel Mode
	CDTO	O	Control Data Output Pin in Serial Mode, IIC= "L".
	CAD1	I	Chip Address 1 Pin in Serial Mode, IIC= "H".
33	CM1	I	Master Clock Operation Mode 1 Pin in Parallel Mode
	CDTI	I	Control Data Input Pin in Serial Mode, IIC= "L".
	SDA	I/O	Control Data Pin in Serial Mode, IIC= "H".
34	OCKS1	I	Output Clock Select 1 Pin in Parallel Mode
	CCLK	I	Control Data Clock Pin in Serial Mode, IIC= "L"
	SCL	I	Control Data Clock Pin in Serial Mode, IIC= "H"
35	OCKS0	I	Output Clock Select 0 Pin in Parallel Mode
	CSN	I	Chip Select Pin in Serial Mode, IIC="L".
	CAD0	I	Chip Address 0 Pin in Serial Mode, IIC= "H".
36	INT0	O	Interrupt 0 Pin
37	INT1	O	Interrupt 1 Pin
38	AVDD	I	Analog Power Supply Pin, 3.3V
39	R	-	External Resistor Pin 18k $\Omega$ +/-1% resistor should be connected to AVSS externally.
40	VCOM	-	Common Voltage Output Pin 0.47 $\mu$ F capacitor should be connected to AVSS externally.
41	AVSS	I	Analog Ground Pin
42	RX0	I	Receiver Channel 0 Pin (Internal biased pin) This channel is default in serial mode.
43	NC(AVSS)	I	No Connect No internal bonding. This pin should be connected to AVSS.
44	RX1	I	Receiver Channel 1 Pin (Internal biased pin)
45	TEST1	I	TEST 1 pin. This pin should be connected to AVSS.
46	RX2	I	Receiver Channel 2 Pin (Internal biased pin)
47	NC(AVSS)	I	No Connect No internal bonding. This pin should be connected to AVSS.
48	RX3	I	Receiver Channel 3 Pin (Internal biased pin)

Note 1. All input pins except internal biased pins should not be left floating.

**D/A CONVERTER IC PIN ASSIGNMENT & BLOCK DIAGRAM** □  
**PIN ASSIGNMENT (TOP VIEW)**

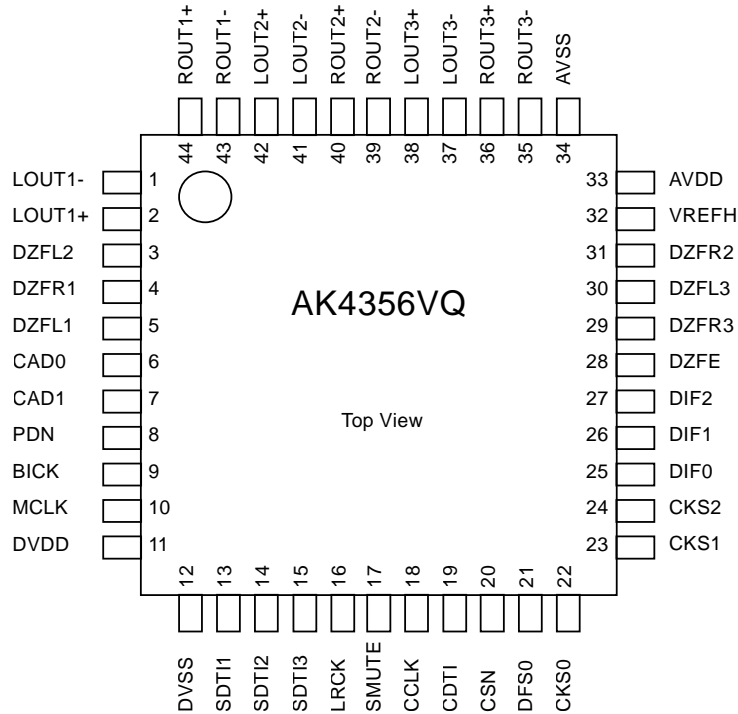

■ **Block Diagram**

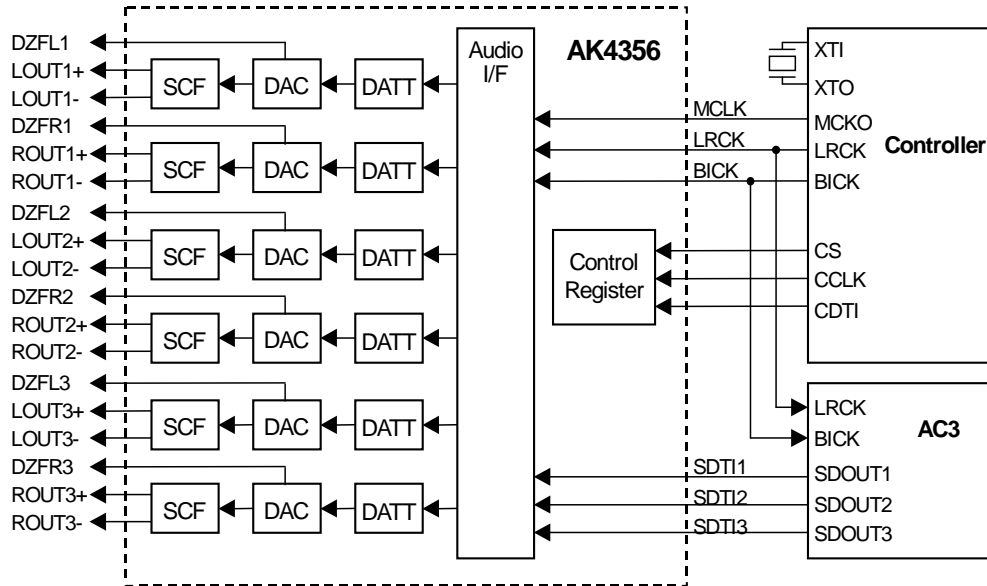

<b>D/A CONVERTER IC PIN FUNCTION (AK4356VQ) : IC78</b>
--

<b>PIN/FUNCTION</b>
---------------------

No.	Pin Name	I/O	Function
1	LOUT1-	O	DAC1 Lch Negative Analog Output Pin
2	LOUT1+	O	DAC1 Lch Positive Analog Output Pin
3	DZFL2	O	DAC2 Lch Zero Input Detect Pin
4	DZFR1	O	DAC1 Rch Zero Input Detect Pin
5	DZFL1	O	DAC1 Lch Zero Input Detect Pin
6	CAD0	I	Chip Address 0 Pin
7	CAD1	I	Chip Address 1 Pin
8	PDN	I	Power-Down & Reset Pin When "L", the AK4356 is powered-down and the control registers are reset to default state. If the state of CAD0-1 changes, then the AK4356 must be reset by PDN.
9	BICK	I	Audio Serial Data Clock Pin
10	MCLK	I	Master Clock Input Pin
11	DVDD	-	Digital Power Supply Pin, +4.75~+5.25V
12	DVSS	-	Digital Ground Pin
13	SDTI1	I	DAC1 Audio Serial Data Input Pin
14	SDTI2	I	DAC2 Audio Serial Data Input Pin
15	SDTI3	I	DAC3 Audio Serial Data Input Pin
16	LRCK	I	Audio Input Channel Clock Pin
17	SMUTE	I	Soft Mute Pin (Note) When this pin goes to "H", soft mute cycle is initialized. When returning to "L", the output mute releases.
18	CCLK	I	Control Data Clock Pin
19	CDTI	I	Control Data Input Pin
20	CSN	I	Chip Select Pin This pin should be held to "H" except for access.

No.	Pin Name	I/O	Function
21	DFS0	I	Double Speed Sampling Mode 0 Pin (Note) “L”: Normal Speed, “H”: Double Speed at DFS1 bit = “0”.
22	CKS0	I	Input Clock Select 0 Pin (Note)
23	CKS1	I	Input Clock Select 1 Pin (Note)
24	CKS2	I	Input Clock Select 2 Pin (Note)
25	DIF0	I	Audio Data Interface Format 0 Pin (Note)
26	DIF1	I	Audio Data Interface Format 1 Pin (Note)
27	DIF2	I	Audio Data Interface Format 2 Pin (Note)
28	DZFE	I	Zero Input Detect Enable Pin (Note)
29	DZFR3	O	DAC3 Rch Zero Input Detect Pin
30	DZFL3	O	DAC3 Lch Zero Input Detect Pin
31	DZFR2	O	DAC2 Rch Zero Input Detect Pin
32	VREFH	I	Positive Voltage Reference Input Pin, AVDD
33	AVDD	-	Analog Power Supply Pin
34	AVSS	-	Analog Ground Pin, +4.75~+5.25V
35	ROUT3-	O	DAC3 Rch Negative Analog Output Pin
36	ROUT3+	O	DAC3 Rch Positive Analog Output Pin
37	LOUT3-	O	DAC3 Lch Negative Analog Output Pin
38	LOUT3+	O	DAC3 Lch Positive Analog Output Pin
39	ROUT2-	O	DAC2 Rch Negative Analog Output Pin
40	ROUT2+	O	DAC2 Rch Positive Analog Output Pin
41	LOUT2-	O	DAC2 Lch Negative Analog Output Pin
42	LOUT2+	O	DAC2 Lch Positive Analog Output Pin
43	ROUT1-	O	DAC1 Rch Negative Analog Output Pin
44	ROUT1+	O	DAC1 Rch Positive Analog Output Pin

Note: SMUTE, DFS0, CKS0, CKS1, CKS2, DIF0, DIF1, DIF2, DZFE pins are ORed with serial control register.

**FAIRCHILD**  
SEMICONDUCTOR™

November 1988

Revised November 1999

# 74AC04 • 74ACT04

## Hex Inverter

74ACT04SC : IC83, 84
----------------------

### General Description

The AC/ACT04 contains six inverters.

### Features

- $I_{CC}$  reduced by 50% on 74AC only
- Outputs source/sink 24 mA
- ACT04 has TTL-compatible inputs

### Ordering Code:

Order Number	Package Number	Package Description
74AC04SC	M14A	14-Lead Small Outline Integrated Circuit (SOIC), JEDEC MS-120, 0.150" Narrow Body
74AC04SJ	M14D	14-Lead Small Outline Package (SOP), EIAJ TYPE II, 5.3mm Wide
74AC04MTC	MTC14	14-Lead Thin Shrink Small Outline Package (TSSOP), JEDEC MO-153, 4.4mm Wide
74AC04PC	N14A	14-Lead Plastic Dual-In-Line Package (PDIP), JEDEC MS-001, 0.300" Wide
74ACT04SC	M14A	14-Lead Small Outline Integrated Circuit (SOIC), JEDEC MS-120, 0.150" Narrow Body
74ACT04MTC	MTC14	14-Lead Thin Shrink Small Outline Package (TSSOP), JEDEC MO-153, 4.4mm Wide
74ACT04PC	N14A	14-Lead Plastic Dual-In-Line Package (PDIP), JEDEC MS-001, 0.300" Wide

Device also available in Tape and Reel. Specify by appending suffix letter "X" to the ordering code. (PC not available in Tape and Reel.)

### Logic Symbol

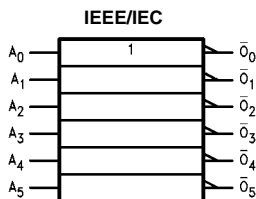

### Connection Diagram

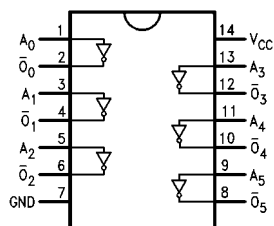

### Pin Descriptions

Pin Names	Description
$A_n$	Inputs
$\bar{O}_n$	Outputs

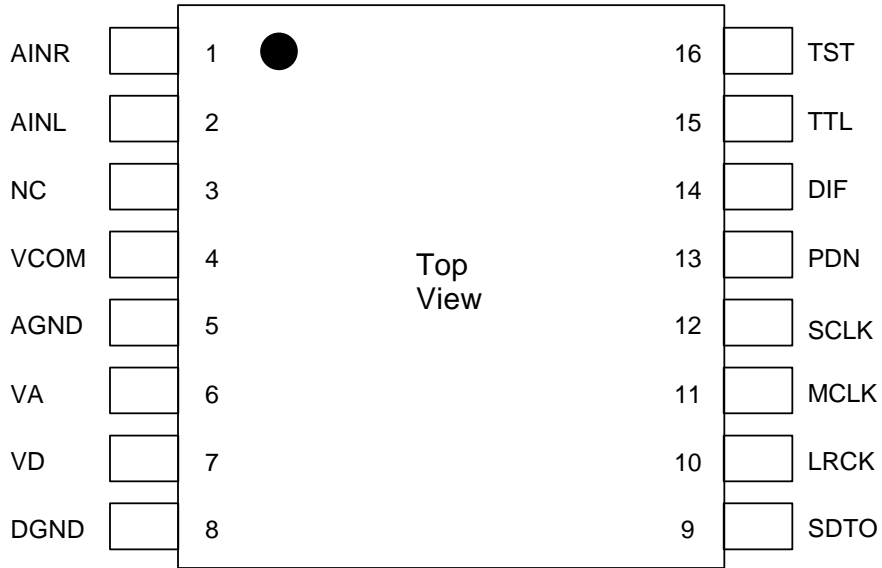

**BLOCK DIAGRAM**

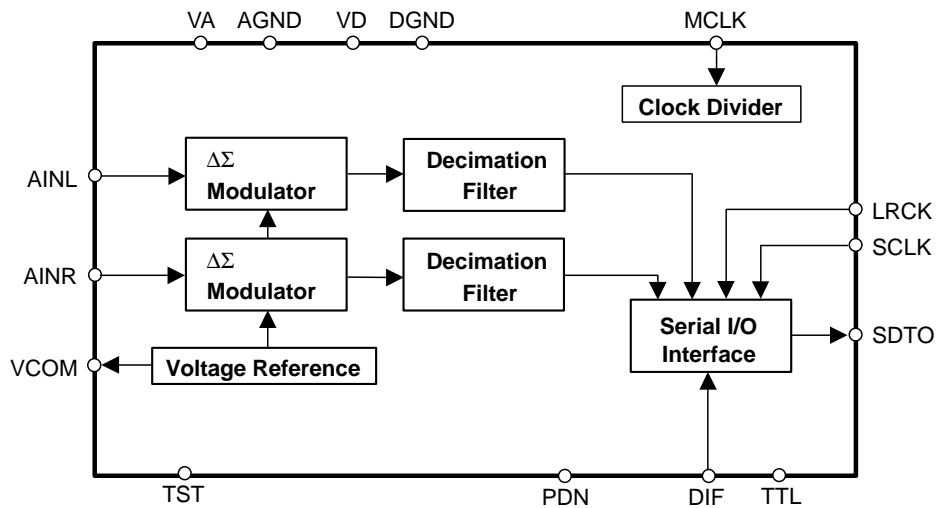

## A/D CONVERTER IC PIN FUNCTION (AK5380VT) : IC77

PIN/FUNCTION			
No.	Pin Name	I/O	Description
1	AINR	I	Rch Analog Input Pin
2	AINL	I	Lch Analog Input Pin
3	NC	-	NC Pin No internal bonding.
4	VCOM	O	Common Voltage Output Pin Normally connected to AGND with a 0.1 $\mu$ F ceramic capacitor in parallel with an electrolytic capacitor less than 2.2 $\mu$ F.
5	AGND	-	Analog Ground Pin, 0V
6	VA	-	Analog Power Supply Pin, +4.5~+5.5V
7	VD	-	Digital Power Supply Pin, +2.7~+5.5V(fs=48kHz), +4.5~+5.5V(fs=96kHz)
8	DGND	-	Digital Ground Pin, 0V
9	SDTO	O	Serial Data Output Pin Data bits are presented MSB first, in 2's complement format. This pin is "L" in the power-down mode.
10	LRCK	I	Left/Right Channel Select Pin The fs clock is input to this pin.
11	MCLK	I	Master Clock Input Pin
12	SCLK	I	Serial Data Input Pin Output data is clocked out on the falling edge of SCLK.
13	PDN	I	Power-Down Pin When "L", the circuit is in power-down mode. The AK5380 should always be reset upon power-up.
14	DIF	I	Serial Interface Format Pin "L": MSB justified, "H": I <sup>2</sup> S
15	TTL	I	Digital Input Level Select Pin "L": CMOS level (VD=2.7~5.5V), "H": TTL level (VD=4.5~5.5V)
16	TST	I	Test Pin (Internal pull-down pin) This pin should be left open.

Note: All input pins except pull-down pins should not be left floating.



■ PIN ASSIGNMENT (74HCU04AFN : IC71,72)

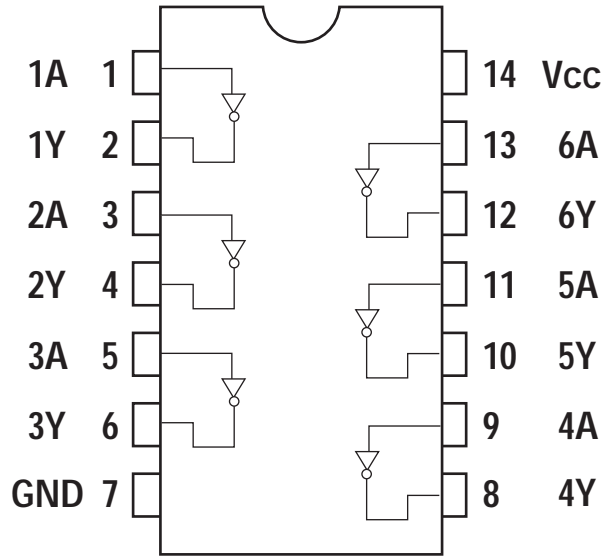

■ LOGIC SYMBOL

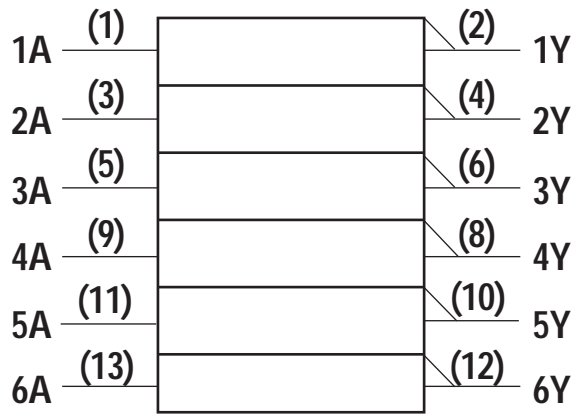

■ TRUTH TABLE

A	Y
L	H
H	L

# CM2054C Display Pattern

Scale 3:1  
Unit : mm

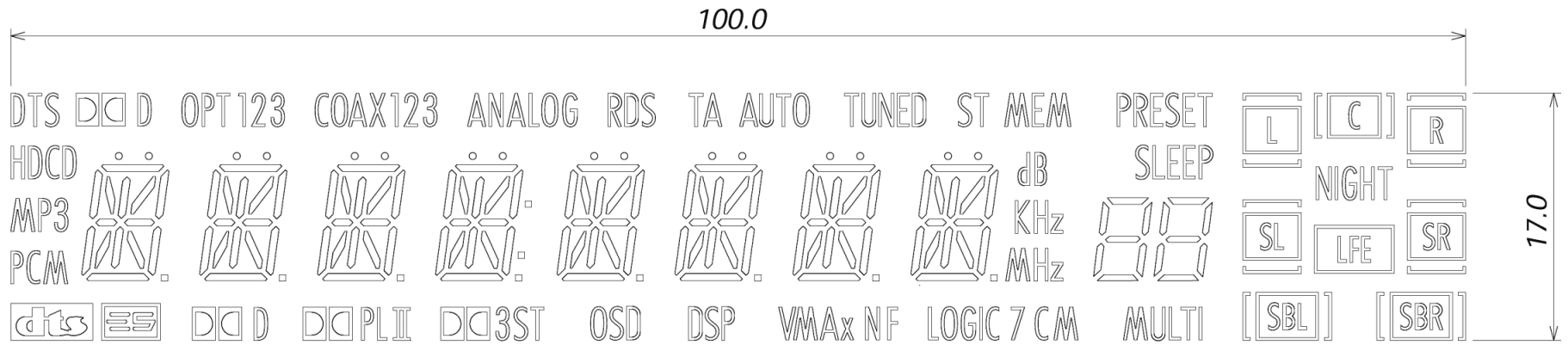

## Color of illumination

G:Green / (Blue Green)

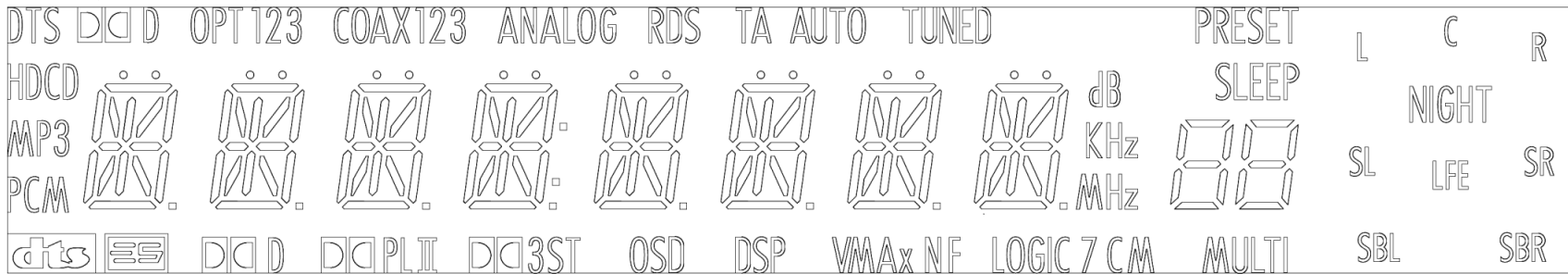

Rsh.O-N:Reddish Orange-N/(Red)

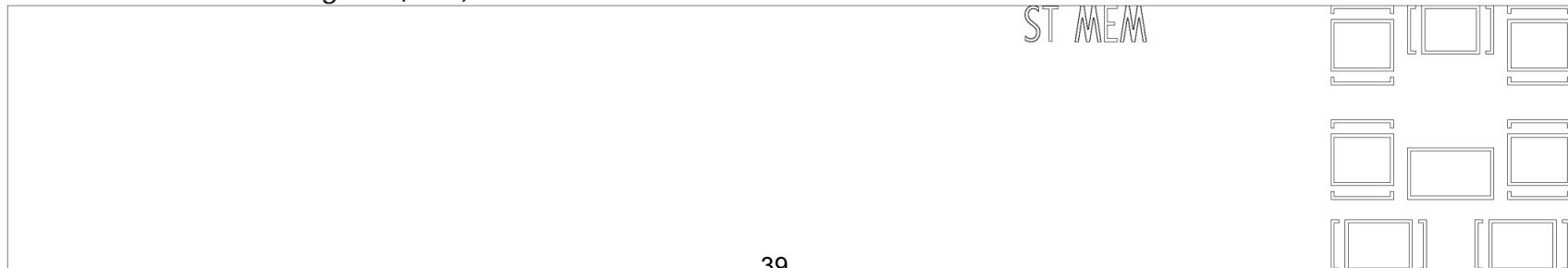

# CM2054C Grid Assignment

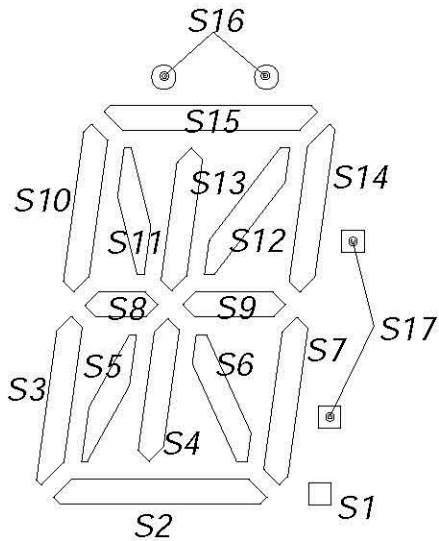
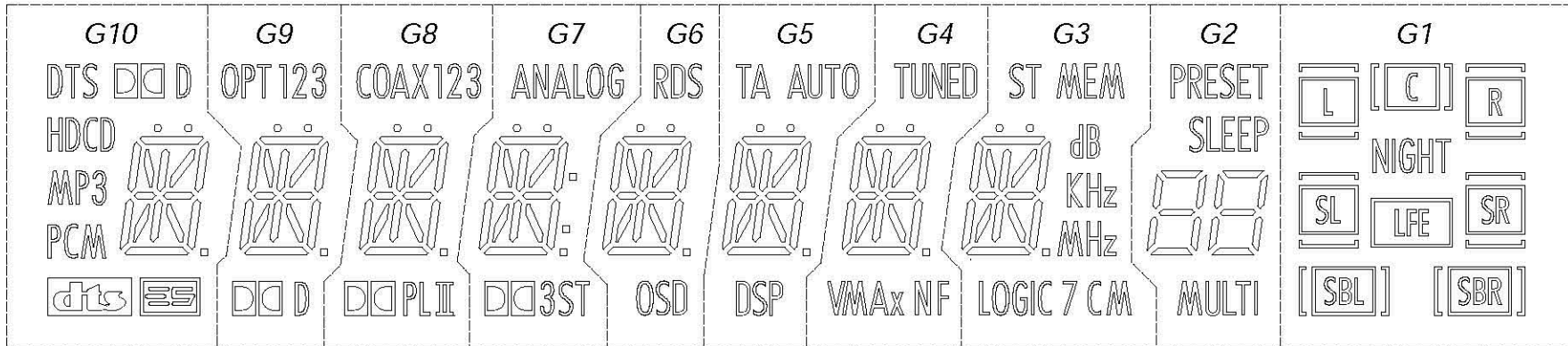

G3-G10

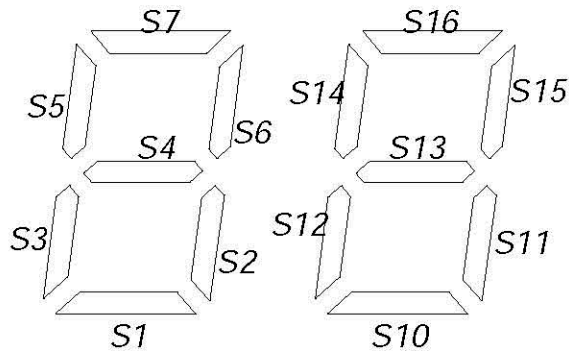

G2

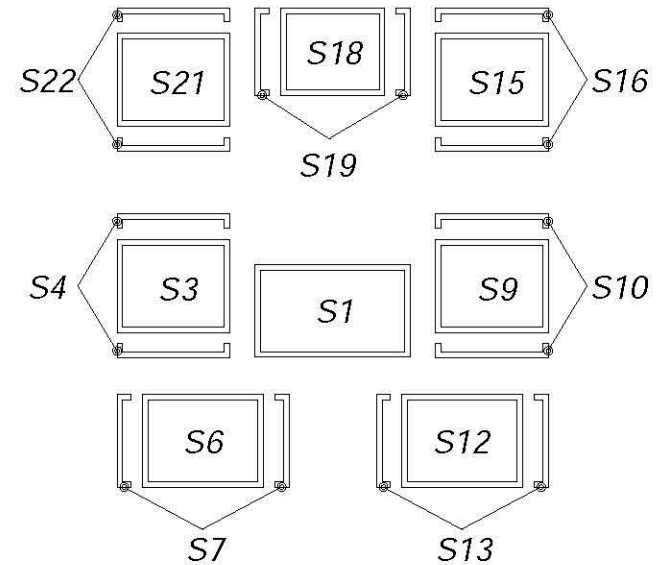

G1

CM2054C:Anode & Grid Assignment

Ise Electronics Corporation

	G1	G2	G3	G4	G5	G6	G7	G8	G9	G10
S1	S1	S1	S1	S1	S1	S1	S1	S1	S1	S1
S2	LFE	S2	S2	S2	S2	S2	S2	S2	S2	S2
S3	S3	S3	S3	S3	S3	S3	S3	S3	S3	S3
S4	S4	S4	S4	S4	S4	S4	S4	S4	S4	S4
S5	SL	S5	S5	S5	S5	S5	S5	S5	S5	S5
S6	S6	S6	S6	S6	S6	S6	S6	S6	S6	S6
S7	S7	S7	S7	S7	S7	S7	S7	S7	S7	S7
S8	SBL		S8	S8	S8	S8	S8	S8	S8	S8
S9	S9		S9	S9	S9	S9	S9	S9	S9	S9
S10	S10	S10	S10	S10	S10	S10	S10	S10	S10	S10
S11	SR	S11	S11	S11	S11	S11	S11	S11	S11	S11
S12	S12	S12	S12	S12	S12	S12	S12	S12	S12	S12
S13	S13	S13	S13	S13	S13	S13	S13	S13	S13	S13
S14	SBR	S14	S14	S14	S14	S14	S14	S14	S14	S14
S15	S15	S15	S15	S15	S15	S15	S15	S15	S15	S15
S16	S16	S16	S16	S16	S16	S16	S16	S16	S16	S16
S17	R		dB				S17			
S18	S18	PRESET	ST	TUNED	TA	RDS	ANALOG	COAX	OPT	DTS
S19	S19	SLEEP	MEM	VMAx	AUTO	OSD	3	1	1	D
S20	C	MULTI	KHz	N	DSP		ST	2	2	HDCD
S21	S21		MHz	F				3	3	MP3
S22	S22		LOGIC 7					PL	D	PCM
S23	L		C					I		dts
S24	NIGHT		M							ES

PIN ASSIGNMENT

Pin No.	46	45	44	43	42	41	40	39	38	37	36	35	34	33	32	31	30	29	28	27	26	25	24	23	22	21	20
Assignment	NL (F2)	F2	NP	NL	S24	S23	S22	S21	S20	S19	S18	S17	S16	S15	S14	S13	S12	S11	S10	S9	S8	S7	S6	S5	S4	S3	S2

Pin No.	19	18	17	16	15	14	13	12	11	10	9	8	7	6	5	4	3	2	1
Assignment	S1	NL	NL	NL	NL	G10	G9	G8	G7	G6	G5	G4	G3	G2	G1	NL	NP	F1	NL (F1)

F1,F2:Filament G1-G10:Grid

S1-S24:Anode NP:No Pin NL:No Lead

## AUDIO DSP (CS493263 - CLG : IC79)

PIN No.	Pin Name	I/O	Function
1,12,23	+VD1	-	Digital Power supply. Normally +2.5v
2,13,24	DGND	-	Digital Ground
3	AUD3	O	SPDIF transmitter output/Digital audio output(N.C)
4	WR	I	Host write strobe pin(connected to GND with an external resistor)
5	RD	I	Host parallel output enable pin(pulled up with an external resistor)
6	CS_DA	I	SPI Serial data input pin
7	CS_CK	I	Serial control clock input pin
8	EMAD7	I/O	Serial data IN/OUTPUT pins(pulled up with an external resistor)
9	EMAD6	I/O	
10	EMAD5	I/O	
11	EMAD4	I/O	
14	EMAD3	I/O	
15	EMAD2	I/O	
16	EMAD1	I/O	
17	EMAD0	I/O	
18	CS_CE	I	Host parallel chip select pin
19	SCDIO(AK_DOUT)	O	Serial control port data ouput pin
20	INTREQ	O	Control port interrupt request output pin
21	EXTMEM	I/O	External Memory Chip Selector(pulled up with an external resistor)
22	SDATAN1(SDI)	I	PCM audio data input number 1 pin
25	SCLKN1(BICK)	I	PCM audio input bit clock pin
26	LRCLKN1(LRCK)	I	PCM audio input sample rate clock pin
27	CMPDAT(SDI)	I	PCM audio data input number 2 pin
28	CMPCLK(BICK)	I	PCM audio input bit clock pin
29	CREQ(LRCK)	I	PCM audio input sample rate clock pin
30	CLKIN(XIN)	I	Master clock input(used external clock)
31	CLKSEL(GND)	I	DSP clock mode select pin: connect the GND
32	FILT1		Connects to an external filter for the on-chip phase-locked loop
33	FILT1		Connects to an external filter for the on-chip phase-locked loop
34	+2.5V	-	Analog Power supply for clock generator . Normally +2.5V
35	AGND	-	Analog ground supply for clock generator PLL.
36	RESET(CS_RST)	I	Master reset input pin
37	DBDATA	-	Reserved pin and should be pulled up with an external resistor.
38	DBCLK	-	Reserved pin and should be pulled up with an external resistor.
39	AUD2(SDO2)	O	PCM multi-format digital-audio data ouput2 pin
40	AUD1(SDO1)	O	PCM multi-format digital-audio data ouput1 pin
41	AUD0(SDO0)	O	PCM multi-format digital-audio data ouput0 pin
42	LRCLK	I	Audio output sample rate clock pin
43	SCLK(BICK)	I	Audio ouput bit clock pin
44	MCLK	I	Audio master clock output pin

**■ PIN ASSIGNMENT.(CS493263)**

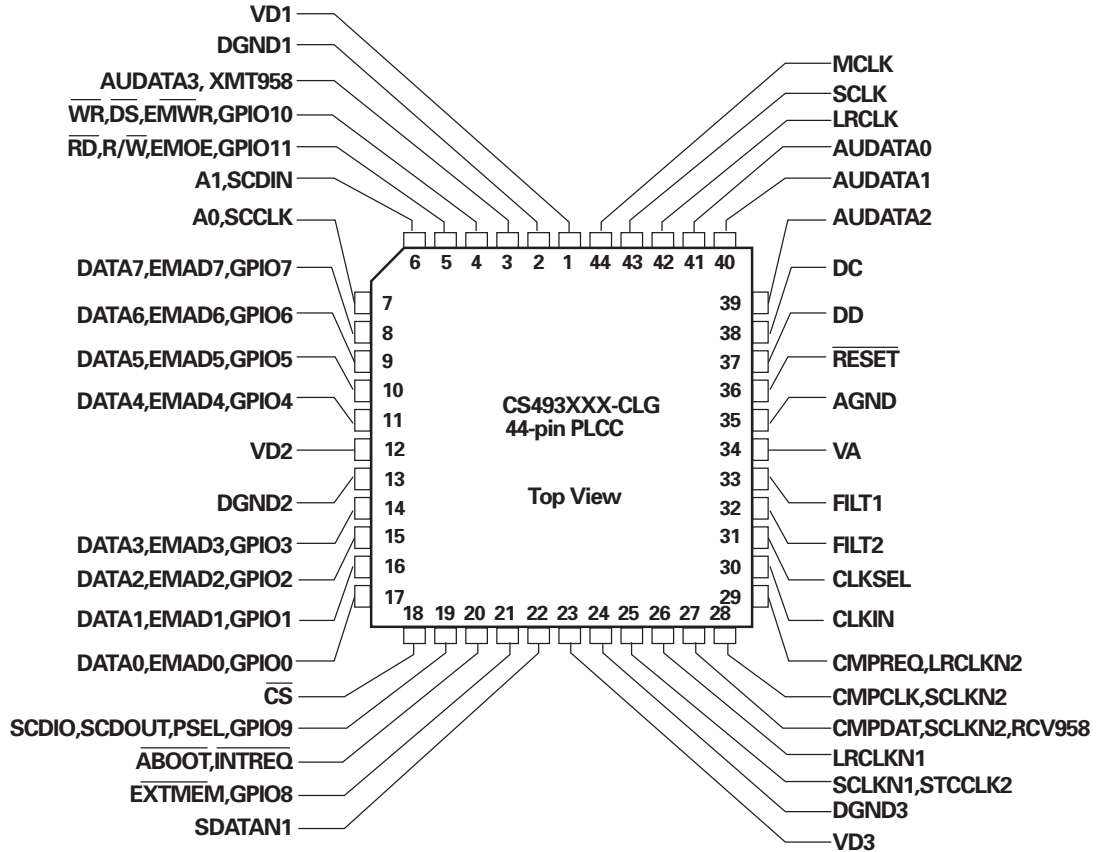

**(TOP VIEW)**

**BLOCK DIAGRAM(CS493263)**

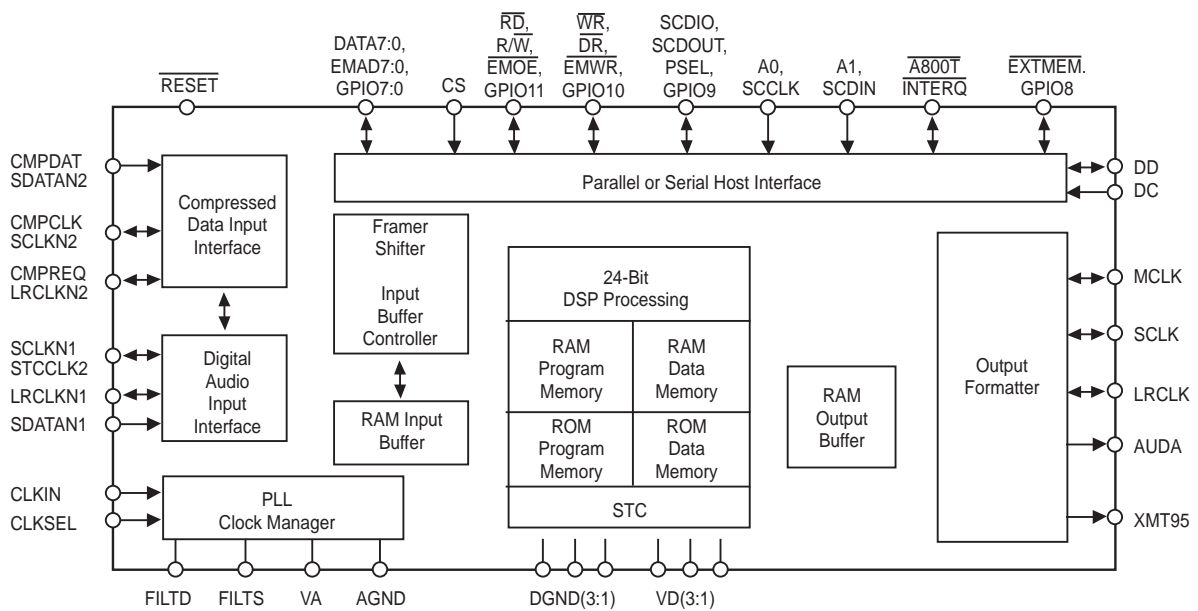

# TC9162AF (FUNCTION/INPUT : IC30)

## ■ BLOCK DIAGRAM

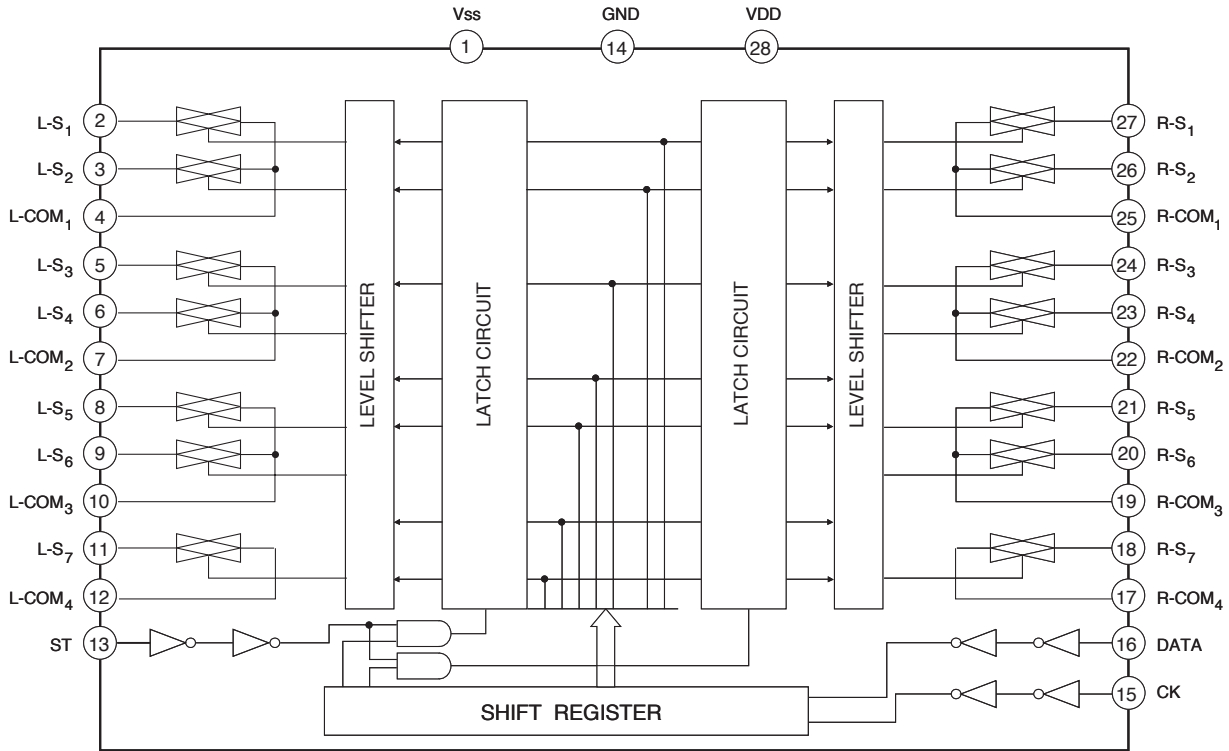

## PIN ASSIGNMENT (TOP VIEW)

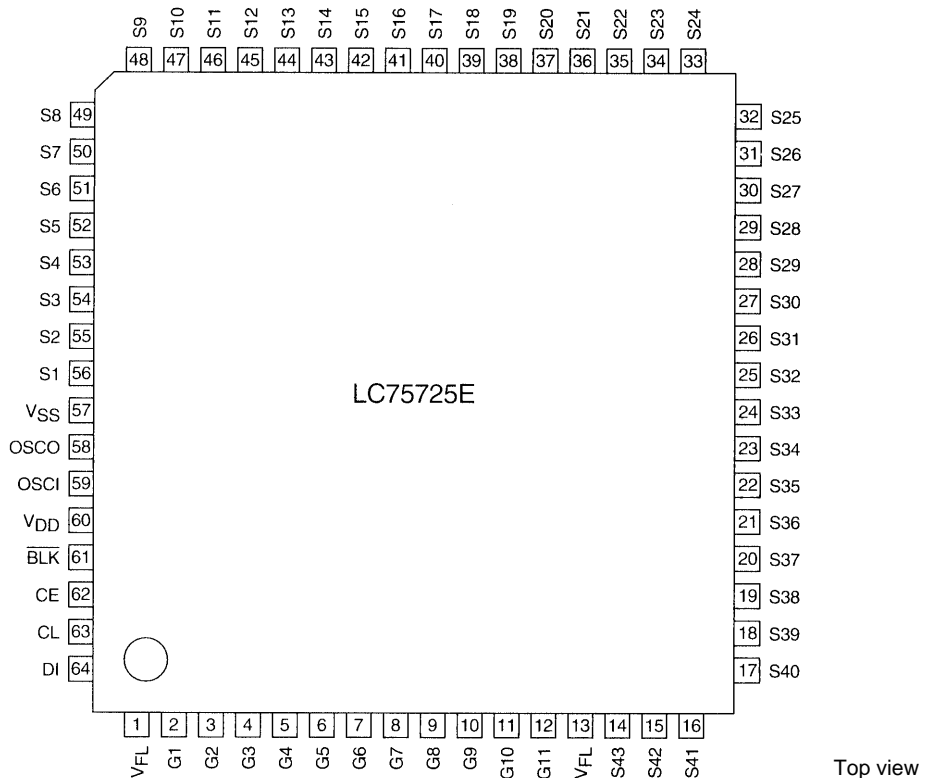

A06732

Top view

**BLOCK DIAGRAM**

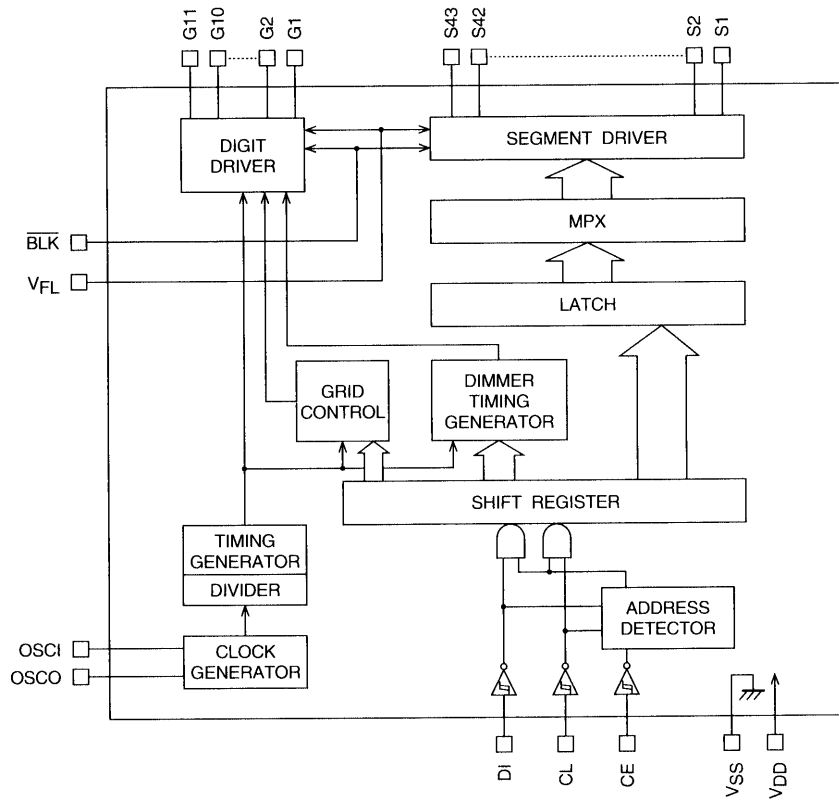

A06735

**VFD DRIVER IC PIN FUNCTION (LC75725E) : IC74**

Pin	Pin No.	Function	I/O	Handling when unused
V <sub>FL</sub>	1, 13	Driver block power supply connection. (Both pins must be connected.)	—	—
V <sub>DD</sub>	60	Logic block power supply connection. Provide a voltage between 4.5 and 5.5 V.	—	—
V <sub>SS</sub>	57	Power supply connection. Connect to the ground.	—	—
OSCI	59	Oscillator connection. An oscillator circuit is formed by connecting an external resistor and capacitor to these pins.	I	GND
OSCO	58		O	OPEN
$\overline{\text{BLK}}$	61	Display off control input. BLK = Low (V <sub>SS</sub> ) ... Display off. (S1 to S43 and G1 to G11 at V <sub>FL</sub> level.) BLK = High (V <sub>DD</sub> ) ... Display on. Note that serial data can be transferred while the display is turned off.	I	GND
CL	63	Serial data transfer inputs. These pins must be connected to the system microcontroller. CL: Synchronization clock DI: Transfer data CE: Chip enable	I	GND
DI	64			
CE	62			
G1 to G11	2 to 12	Digit outputs. These pins are P-channel open drain outputs with pull-down resistors.	O	OPEN
S1 to S43	56 to 14	Segment outputs for displaying the display data transferred by serial data input. These pins are P-channel open drain outputs with pull-down resistors.	O	OPEN



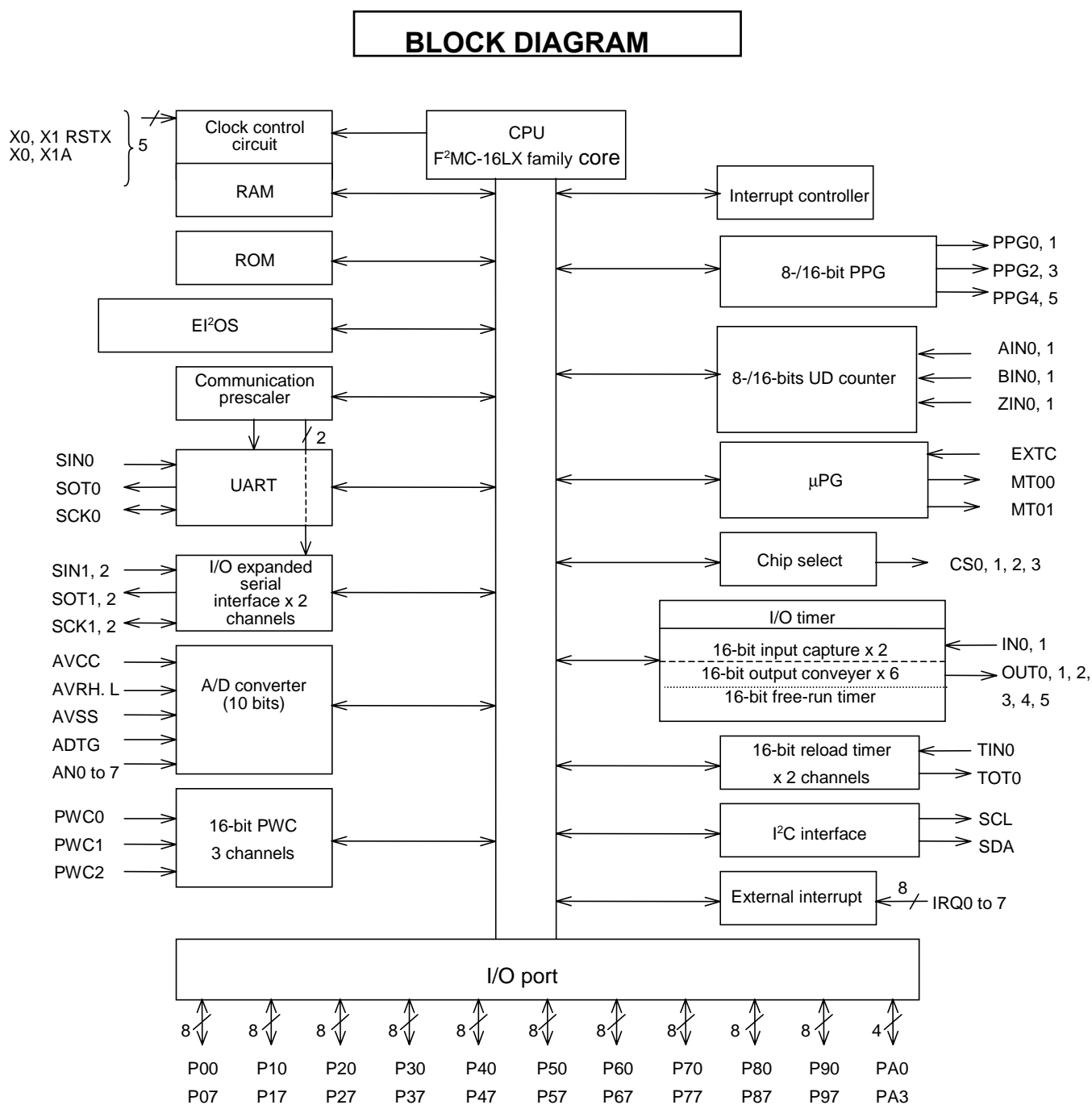

**Fig. 1.1 Block Diagram (MB90470)**

P00 to P07 (8): Provided with input pull-up resistor setting register

P10 to P17 (8): Provided with input pull-up resistor setting register

P40 to P47 (8): Provided with open-drain setting register

P70 to P75 (6): Provided with open-drain setting register

P76 to P77 (2): Open-drain

**Note:** In the figure above, the I/O port shares the pins with each internal functional block. When the pins are used as internal module pins, they cannot be used as I/O port pins.



**M-COM IC PIN ASSIGNMENT & BLOCK DIAGRAM □**  
**PIN ASSIGNMENT (TOP VIEW)**

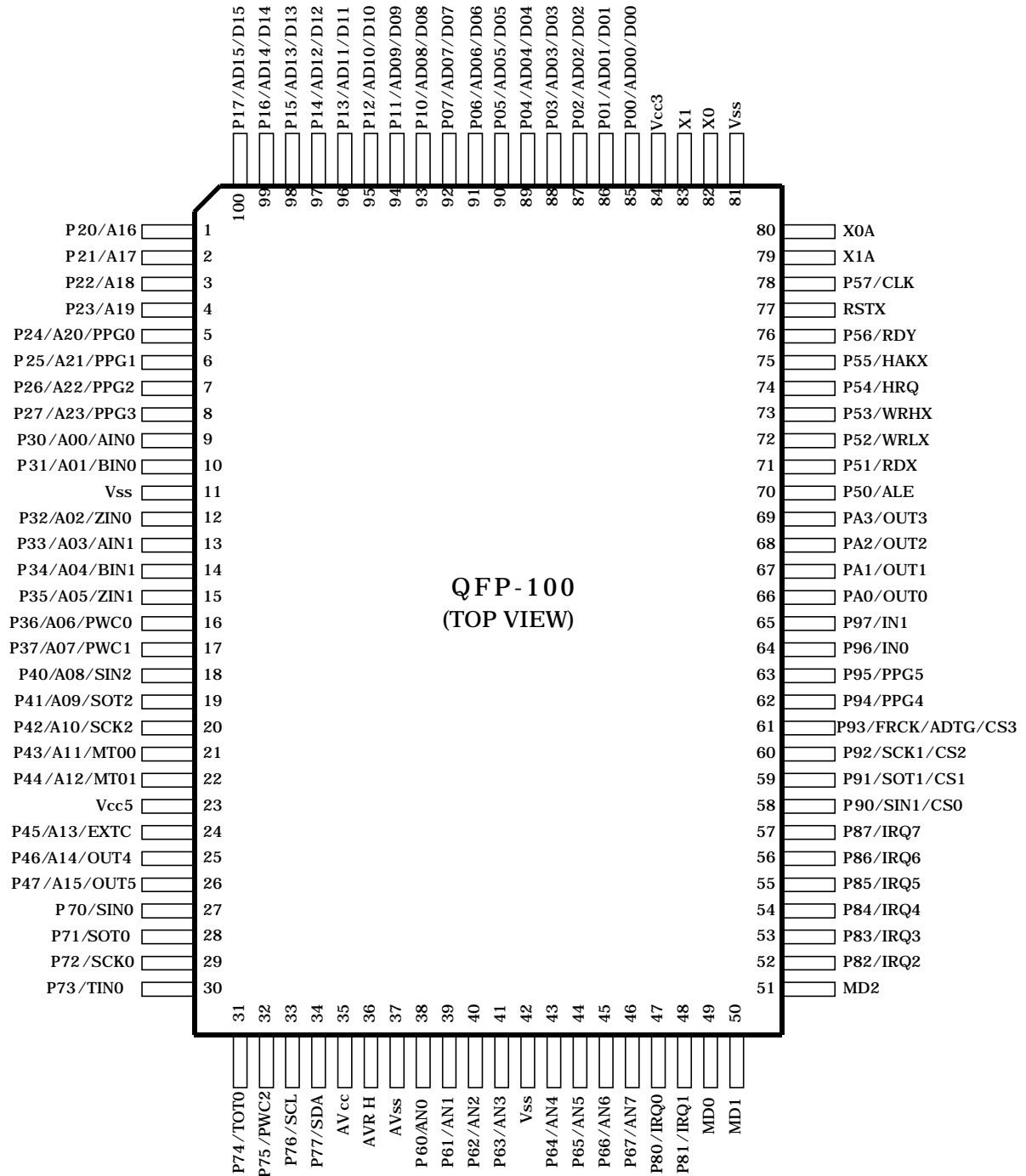

P20-27/P30-37/P40-47/P70-77: 5 V-I/F



<b>IC PIN FUNCTION (M-COM : MB90F476APFG) : IC72</b>
--

LQFP	QFP	Pin Name	Circuit Type	Function
80	82	X0	A	Oscillator pin
81	83	X1	A	Oscillator pin
78	80	X0A	A	32 kHz Oscillator pin
77	79	X1A	A	32 kHz Oscillator pin
75	77	RSTX	B	Reset input pin
83 to 90	85 to 92	P00 to P07	C (CMOS)	General-purpose I/O ports A pull-up resistor can be attached using the pull-up resistor setting register (RDR0) (RD07 to RD00 = 1). (Invalid when set to output)
		AD00 to AD07		In the multiplex mode, the pins function as external address/data bus lower I/O pins.
		D00 to D07		In the non-multiplex mode, they function as external data bus lower output pins.
91 to 98	93 to 100	P10 to P17	C (CMOS)	General-purpose I/O ports A pull-up resistor can be attached using the pull-up resistor setting register (RDR1) (RD17 to RD10 = 1). (Invalid when set to output)
		AD08 to AD15		In the multiplex mode, the pins function as external address/data bus upper I/O pins.
		D08 to D15		In the non-multiplex mode, they function as external data upper output pins.
99 100 1 and 2	1 to 4	P20 to P23	E (CMOS/H)	General-purpose I/O ports When the corresponding bit of the HACR register is 0, the pins function as address upper output pins (A20 to A23).
		A16 to A19		When the multiplex mode is enabled and the corresponding bit of the HACR register is 1, the pins function as general-perpose I/O port.
		A16 to A19		In the non-multiplex mode, they function as external address upper output pins.
3 to 6	5 to 8	P24 to P27	E (CMOS/H)	General-purpose I/O ports When the corresponding bit of the HACR register is 0, the pins function as address upper output pins (A20 to A23).
		A20 to A23		When the multiplex mode is enabled and the corresponding bit of the HACR register is 1, the pins function as general-perpose I/O port.
		A20 to A23		In the non-multiplex mode, they function as external address upper output pins.
		PPG0 to 3		The pins function as PPG timer output pin.



LQFP	QFP	Pin Name	Circuit Type	Function
7	9	P30	E (CMOS/H)	General-purpose I/O ports
		A00		In the external bus mode, the pin functions as an external address pin.
		AIN0		The pin is an 8-/16-bit up-and-down timer input pin (ch0).
8	10	P31	E (CMOS/H)	General-purpose I/O port
		A01		In the external bus mode, the pin functions as an external address pin.
		BIN1		The pin is the 8-/16-bit up-and-down timer input pin (ch0).
10	12	P32	E (CMOS/H)	General-purpose I/O port
		A02		In the external bus mode, the pin functions as an external address pin.
		ZIN0		The pin is an 8-/16-bit up-and-down timer input pin (ch0).
11	13	P33	E (CMOS/H)	General-purpose I/O port
		A03		In the external bus mode, the pin functions as an external address pin.
		AIN1		The pin is an 8-/16-bit up-and-down timer input pin (ch1).
12	14	P34	E (CMOS/H)	General-purpose I/O port
		A04		In the external bus mode, the pin functions as an external address pin.
		BIN1		The pin is an 8-/16-bit up-and-down timer input pin (ch1).
13	15	P35	E (CMOS/H)	General-purpose I/O port
		A05		In the external bus mode, the pin functions as an external address pin.
		ZIN1		The pin is an 8-/16-bit up-and-down timer input pin (ch1).
14 and 15	16 and 17	P36, P37	E (CMOS/H)	General-purpose I/O port
		A06, A07		In the external bus mode, the pins function as external address pins.
		PWC0, PWC1		This pin functions as PWC input pin.
16	18	P40	G (CMOS/H)	General-purpose I/O port
		A08		In the external bus mode, the pin functions as an external address pin.
		SIN2		Simple serial I/O input pin
17	19	P41	F (CMOS/H)	General-purpose I/O port
		A09		In the external bus mode, the pin functions as an external address pin.
		SOT2		SCI Output pin
18	20	P42	G (CMOS)	General-purpose I/O port
		A10		In the external bus mode, the pin functions as an external address pin.
		SCK2		SCI Clock I/O pin
19 and 20	21 and 22	P43, P44	F (CMOS)	General-purpose I/O port
		A11, A12		In the external bus mode, the pins function as external address pins.
		MT00, MT01		μPG Output pins
22	24	P45	G (CMOS)	General-purpose I/O port
		A13		In the external bus mode, the pin functions as an external address pin.
		EXTC		μPG Input pin
23 and 24	25 and 26	P46, P47	D (CMOS)	General-purpose I/O ports
		A14, A15		In the external bus mode, the pins function as external address pins.
		OUT4/ OUT5		The pins are captured as output-compare event output pins.



LQFP	QFP	Pin Name	Circuit Type	Function
68	70	P50	D (CMOS)	General-purpose I/O port In the external bus mode, the pin functions as ALE pin.
		ALE		In the external bus mode, the pin functions as an address capture enable signal (ALE) pin.
69	71	P51	D (CMOS)	General-purpose I/O port In the external bus mode, the pin functions as the RDX pin.
		RDX		When the external bus mode is enabled, the pin functions as the read strobe output (RDX) pin.
70	72	P52	D (CMOS)	General-purpose I/O port When the external bus mode is enabled and the WRE bit of the EPCR register is 1, the pin functions as the WRLX pin
		WRLX		When the external bus mode is enabled, the pin functions as the lower-order side data write strobe output (WRLX) pin. When the WRE bit of the EPCR register is 0, the pin functions as a general-purpose I/O port.
71	73	P53	D (CMOS)	General-purpose I/O port When the external bus mode is enabled (the bus is 16-bits long) and the WRE bit of the EPCR register is 1, the pin functions as the WRHX pin.
		WRHX		When the external bus mode is enabled (the bus is 16-bits long), the pin functions as the higher-order side data write strobe output (WRHX) pin. When the WRE bit of the EPCR register is 0, the pin functions as a general-purpose I/O port.
72	74	P54	D (CMOS)	General-purpose I/O port When the external bus mode is enabled and the HDE bit of the EPCR register is 1, the pin functions as the HRQ pin.
		HRQ		When the external bus mode is enabled, the pin functions as the hold request input (HRQ) pin. When the HDE bit of the EPCR register is 0, the pin functions as a general-purpose I/O port.
73	75	P55	D (CMOS)	General-purpose I/O port When the external bus mode is enabled and the HDE bit of the EPCR register is 1, the pin functions as the HAKX pin.
		HAKX		When the external bus mode is enabled, the pin functions as the hold acknowledge output (HAKX) pin. When the HDE bit of the EPCR register is 0, the pin functions as a general-purpose I/O port.
74	76	P56	D (CMOS)	General-purpose I/O port When the external bus mode is enabled and the RYE bit of the EPCR register is 1, the pin functions as the RDY pin.
		RDY		When the external bus mode is enabled, the pin functions as the external ready input (RDY) pin. When the RYE bit of the EPCR register is 0, the pin functions as a general-purpose I/O port.
76	78	P57	D (CMOS)	General-purpose I/O port When the external bus mode is enabled and the CKE bit of the EPCR register is 1, the pin functions as the CLK pin.
		CLK		When the external bus mode is enabled, the pin functions as the machine cycle clock output (CLK) pin. When the CKE bit of the EPCR register is 0, the pin functions as a general-purpose I/O port.
36 to 39	38 to 41	P60 to P63	H (CMOS)	General-purpose I/O port
		AN0 to AN3		The pins function as analog input pins.
41 to 44	43 to 46	P64 to P67	H (CMOS)	General-purpose I/O port
		AN4 to AN7		The pins function as analog input pins.
25	27	P70	G (CMOS/H)	General-purpose I/O port
		SIN0		The pin functions as an UART data input pin.

LQFP	QFP	Pin Name	Circuit Type	Function
26	28	P71	F (CMOS)	General-purpose I/O port
		SOT0		The pin functions as an UART data output pin.
27	29	P72	G (CMOS/H)	General-purpose I/O port
		SCK0		The pin functions as an UART clock I/O pin.
28	30	P73	G (CMOS/H)	General-purpose I/O port
		TIN0		The pin functions as the event input pin of the 16-bit reload timer.
29	31	P74	F (CMOS/H)	General-purpose I/O port
		TOT0		The pin functions as the output pin of the 16-bit reload timer.
30	32	P75	G (CMOS/H)	General-purpose I/O port
		PWC2		The pin functions as a PWC input pin.
31	33	P76	I (NMOS/H)	General-purpose I/O port
		SCL		The pin functions as the I <sup>2</sup> C interface data I/O pin. While the I <sup>2</sup> C interface is operating, set the port output to Hi-Z.
32	34	P77	I (NMOS/H)	General-purpose I/O port
		SDA		The pin functions as the I <sup>2</sup> C interface clock I/O pin. While the I <sup>2</sup> C interface is operating, set the port output to Hi-Z.
45	47	P80, P81	E (CMOS/H)	General-purpose I/O port
46	48	IRQ0, IRQ1		The pins function as external interrupt input pins.
50 to 55	52 to 57	P82 to P87	E (CMOS/H)	General-purpose I/O port
		IRQ2 to IRQ7		The pins function as external interrupt input pins.
56	58	P90	E (CMOS/H)	General-purpose I/O port
		SIN1		The pin functions as the simple serial I/O data input pin.
		CS0		Chip select 0
57	59	P91	D (CMOS)	General-purpose I/O port
		SOT1		The pin functions as the I/O clock I/O pins.
		CS1		Chip Select 1
58	60	P92	E (CMOS/H)	General-purpose I/O port
		SCK1		The pin functions as the SCI clock I/O pin.
		CS2		Chip Select 2
59	61	P93	E (CMOS/H)	General-purpose I/O port
		FRCK		The pin functions as the external clock input pin while the free-running timer is in use.
		ADTG		The pin functions as the external trigger input pin while the A/D converter is in use.
		CS3		Chip Select 3
60	62	P94	D (CMOS/H)	General-purpose I/O port
		PPG4		The pin functions as a PPG timer output pin.
61	63	P95	D (CMOS)	General-purpose I/O port
		PPG5		The pin functions as a PPG timer output pin.
62	64	P96	E (CMOS/H)	General-purpose I/O port
		IN0		The pin is captured as the input capture ch0 trigger input pin.
63	65	P97	E (CMOS/H)	General-purpose I/O port
		IN1		The pin is captured as the input capture ch1 trigger input pin.
64 to 67	66 to 69	PA0 to PA3	D (CMOS)	General-purpose I/O port
		OUT0 to OUT3		The pins are captured as the output-compare event output pins.
33	35	AVCC	-	Pin for power supply to A/D converter
34	36	AVRH	-	Pin for external reference power supply to A/D converter
35	37	AVSS	-	Pin for power supply to A/D converter
47 to 49	49 to 51	MD0 to MD2	J (CMOS/H)	Input pins for selecting operation mode
82	84	VCC3	-	Pin for power supply 3.3 V ± 0.3 V (VCC3)
21	23	VCC5	-	Amphibious pin for power supply 3.3 V ± 0.3 V/5.0 V ± 0.5 (VCC5)
9	11	VSS	-	Pins for input for power (GND)
40	42			
79	81			



NJM2068M : IC23~29 , 32~34 , 82,88

NJM2068

**LOW-NOISE DUAL OPERATIONAL AMPLIFIER**

■ **GENERAL DESCRIPTION**

The NJM2068 is a high performance, low noise dual operational amplifier. This amplifier features popular pin-out, superior noise performance, and superior total harmonic distortion. This amplifier also features guaranteed noise performance with substantially higher gain-bandwidth product and slew rate which far exceeds that of the 4558 type amplifier. The specially designed low noise input transistors allow the NJM2068 to be used in very low noise signal processing applications such as audio preamplifiers and servo error amplifier.

■ **PACKAGE OUTLINE**

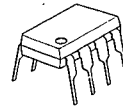

NJM2068D



NJM2068M



NJM2068V

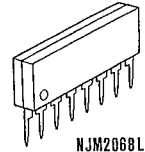

NJM2068L

■ **FEATURES**

- Operating Voltage (±4V ~ ±18V)
- Low Total Harmonic Distortion (0.001% typ.)
- Low Noise Voltage (FLAT+JISA, 0.56 μV typ.)
- High Slew Rate (6V/μs typ.)
- Unity Gain Bandwidth (27MHz @f=10kHz)
- Package Outline DIP8, DMP8, SIP8, SSOP8
- Bipolar Technology

■ **PIN CONFIGURATION**

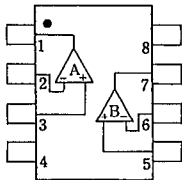

NJM2068D  
NJM2068M  
NJM2068V

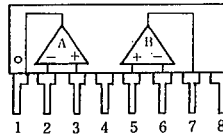

NJM2068L

**PIN FUNCTION**

1. A OUTPUT
2. A-INPUT
3. A+INPUT
4. V-
5. B+INPUT
6. B-INPUT
7. B OUTPUT
8. V+

■ **EQUIVALENT CIRCUIT** (1/2 Shown)

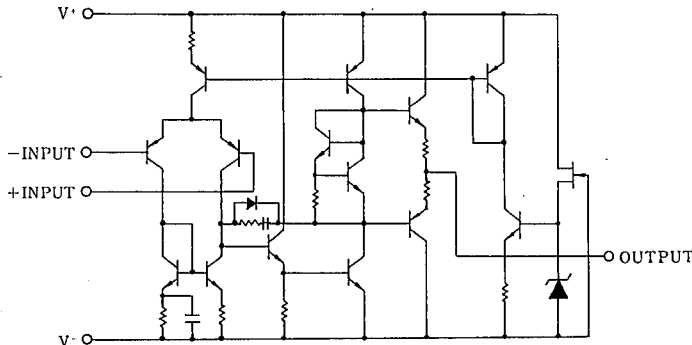

■ BLOCK DIAGAM (NJM2296M) : IC41, 43, 44

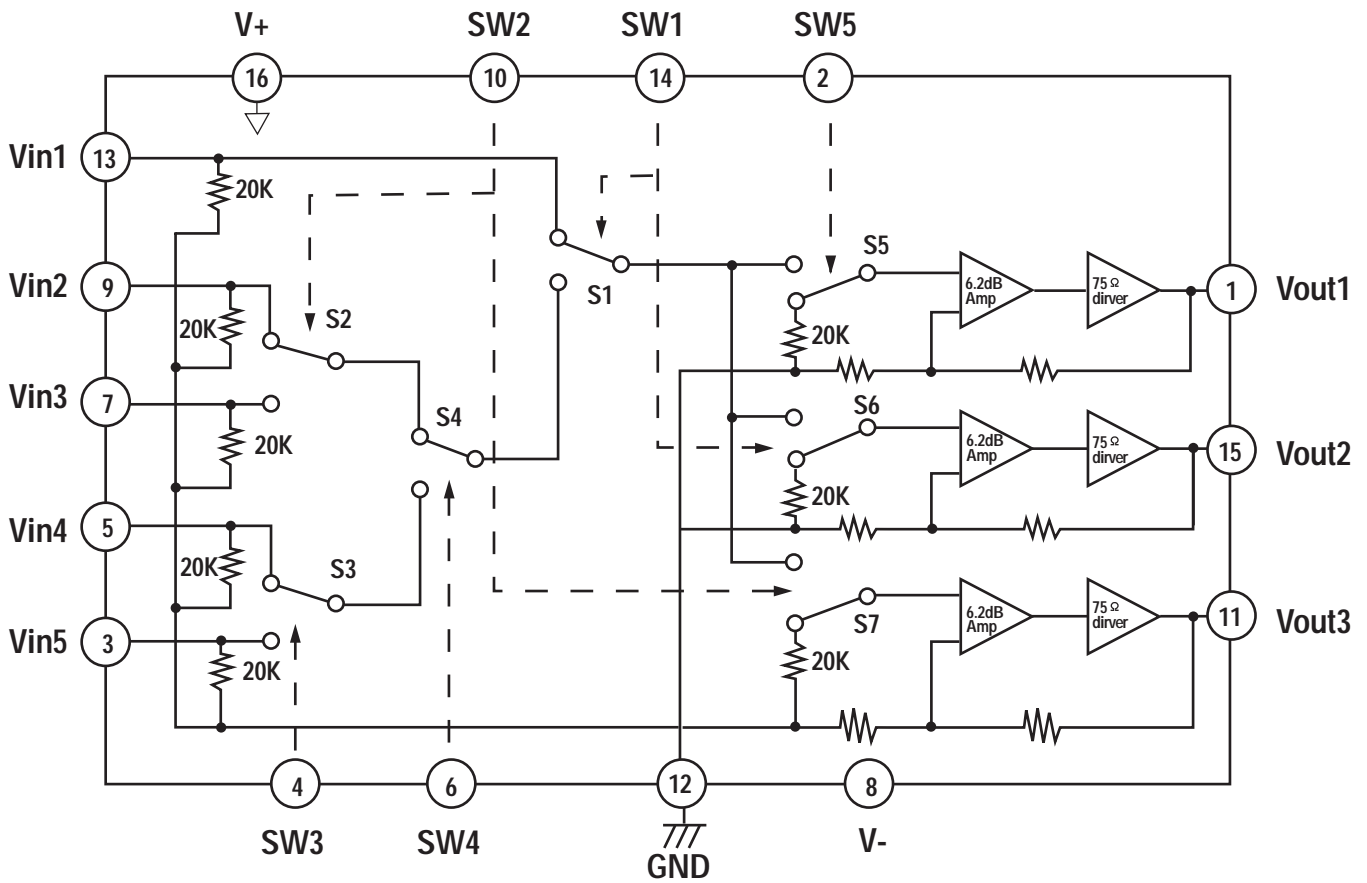

**\* Normally mute**  
**Above circuits show that the switches are set at low.**



NJM4556AM : IC86



NJM4556A

DUAL HIGH CURRENT OPERATIONAL AMPLIFIER

■ GENERAL DESCRIPTION

The NJM4556A integrated circuit is a high-gain, high output current dual operational amplifier capable of driving  $\pm 70\text{mA}$  into  $150\ \Omega$  loads ( $\pm 10.5\text{V}$  output voltage), and operating low supply voltage ( $V^+/V^- = \pm 2\text{V} \sim$ ).

The NJM4556A combines many of the fetures of the popular NJM4558 as well as having the capability of driving  $150\ \Omega$  loads. In addition, the wide band-width, low noise, high slew rate and low distortion of the NJM4556A make it ideal for many audio, telecommu- nications and instrumentation applications.

■ FEATURES

- Operating Voltage ( $\pm 2\text{V} \sim \pm 18\text{V}$ )
- High Output Current ( $I_o = 70\text{mA}$ )
- Slew Rate ( $3\text{V}/\mu\text{s}$  typ.)
- Gain Band Width Product ( $8\text{MHz}$  typ.)
- Package Outline DIP8, DMP8, SIP8, SSOP8
- Bipolar Technology

■ PACKAGE OUTLINE

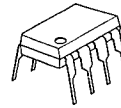

NJM4556AD



NJM4556AM

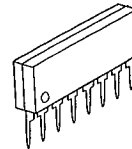

NJM4556AL



NJM4556AV

■ PIN CONFIGURATION

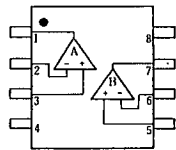

NJM4556AD  
NJM4556AM  
NJM4556AV

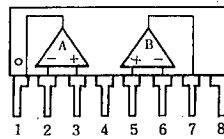

NJM4556AL

- PIN FUNCTION
1. A OUTPUT
  2. A-INPUT
  3. A+INPUT
  4. V-
  5. B+INPUT
  6. B-INPUT
  7. B OUTPUT
  8. V+

■ EQUIVALENT CIRCUIT (1/2 Shown)

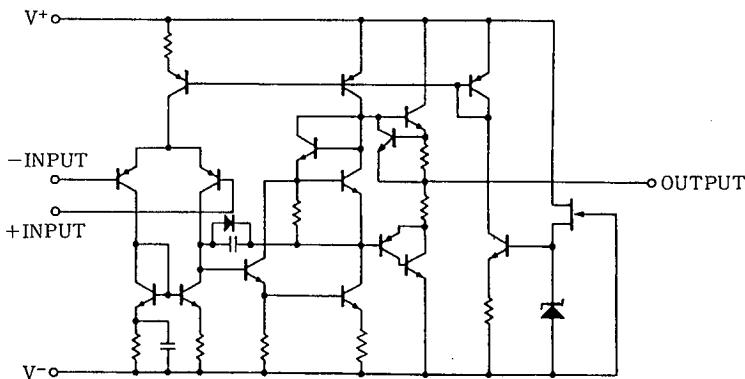

### TC9164AF (FUNCTION/INPUT) : IC22

■ BLOCK DIAGRAM

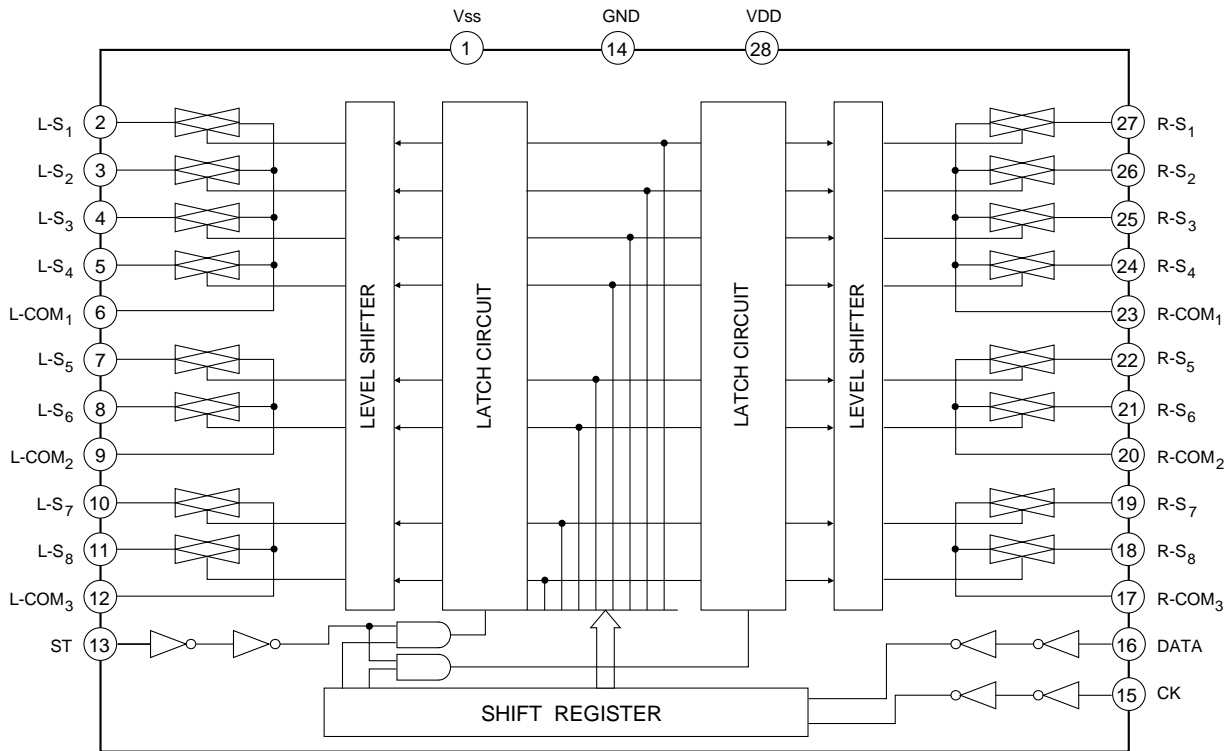

### TC9163AF (FUNCTION/INPUT) : IC20

■ BLOCK DIAGRAM

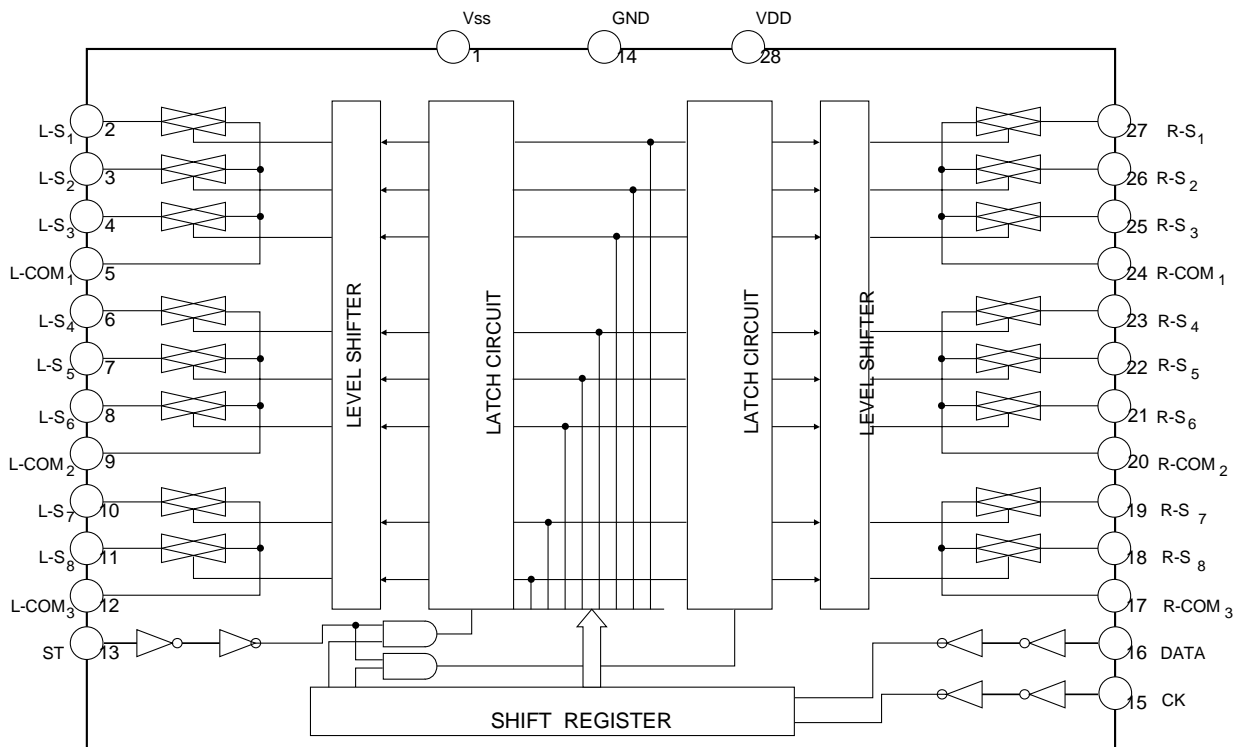

**TC9482F (ELECTRONIC VOLUME/INPUT) : IC31**

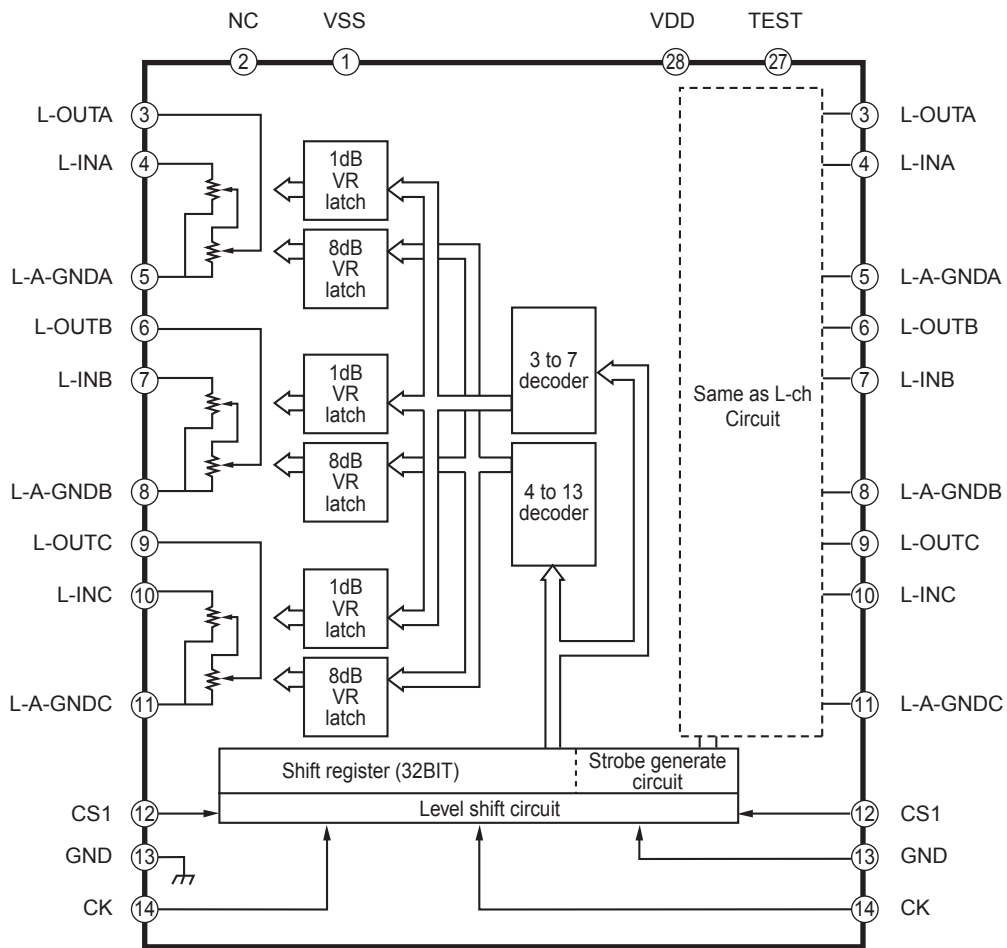





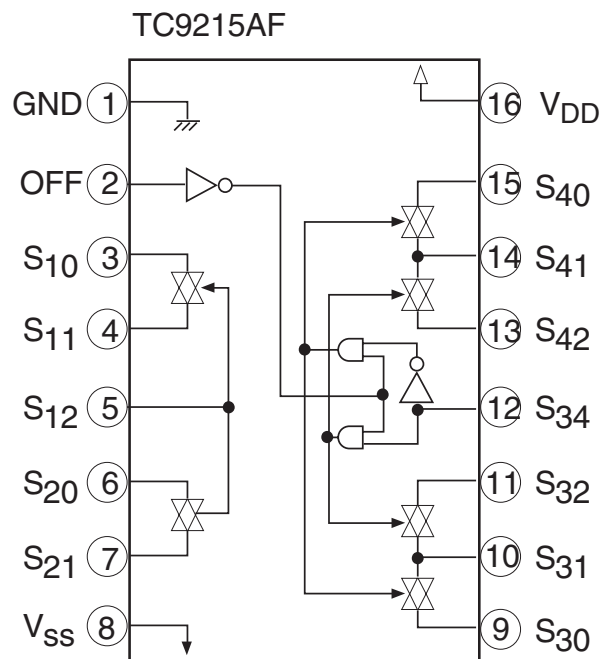



**TC9215AF (TONE CONTROL : IC80)**

■ **BLOCK DIAGRAM**



### TRANSISTOR, REGULATOR IC BLOCK DIAGRAM

<p>TO-92M</p>  <p>1. Emitter 2. Collector 3. Base</p> <p><b>123</b></p> <p>KTC2874B    KSC2785Y KRA107M    KRC107M</p>	<p>TO-92</p>  <p>1. Emitter 2. Collector 3. Base</p> <p><b>123</b></p> <p>KTD1302T    KTA1268GR KTC3200GR    KTC3198Y KTA1271Y</p>	<p>TO-220</p>  <p>1. GND 2. INPUT 3. OUTPUT</p> <p><b>123</b></p> <p>MCNJM7905    MC7915C</p>	<p>TO-92L</p>  <p>1. Emitter 2. Collector 3. Base</p> <p><b>123</b></p> <p>KTA1024Y    KSC2316Y</p>
<p>TO-126</p>  <p>1. Emitter 2. Collector 3. Base</p> <p><b>123</b></p> <p>2SA1360O    2SC3423O KTD600KG</p>	<p>TO-220</p>  <p>1. Base 2. Collector 3. Emitter</p> <p><b>123</b></p> <p>KSA614Y</p>	<p>TO-220</p>  <p>1. INPUT 2. GND 3. OUTPUT</p> <p><b>123</b></p> <p>MC7815C    MC7805C</p>	<p>TO-3P</p>  <p>1. Base 2. Collector 3. Emitter</p> <p><b>1 2 3</b></p> <p>2SB1560 2SD2390</p>

## AVR125 ELECTRICAL PARTS LIST

Reference Designator	Part Number	Description	
<b>PCB , FRONT</b>			
<i>Capacitors</i>			
C703	HCBS1H821KBT	CAP , CERAMIC	820PF 50V K
C704,735,773,774,777,778,864	HCEA1VH100T	CAP , ELECT	10UF 35V
C712	HCEA1HH1R0T	CAP , ELECT	1UF 50V
C713,730,732,736,770,771,805, 806,858-862	HCBS1H223ZFT	CAP , CERAMIC	0.022UF 50V Z
C714,775,776	HCBS1H151KBT	CAP , CERAMIC	150PF 50V K
C716,872,873	HCEA1CH331T	CAP , ELECT	330UF 16V
C719~721	HCBS1H181KBT	CAP , CERAMIC	180PF 50V K
C722	HCBS1H220JT	CAP , CERAMIC	22PF 50V J
C723,807	CCFT1H104ZF	CAP , SEMI	0.1UF 50V ZF
C725,729,865	CCKT1H473ZF	CAP , CERAMIC	0.047UF 50V ZF
C726,863,886	HCEA0JH102T	CAP , ELECT	1000UF 6.3V
C731	HCEA1HH100T	CAP , ELECT	10UF 50V
C733	HCEA1EH470T	CAP , ELECT	47UF 25V
C737,738	HCBS1H180JT	CAP , CERAMIC	18PF 50V J
C779,780,791,792,868,869	HCEA1CKS470T	CAP , ELECT	47UF 16V
C781,782,787~790,866,867	HCEA1CKS100T	CAP , ELECT	10UF 16V
C783,784,855,856	HCBS1H101KBT	CAP , CERAMIC	100PF 50V K
C785,786,850,851	HCBS1H470JT	CAP , CERAMIC	47PF 50V J
C793,794,799,800	KCFE1J183JBT	CAP , FILM	0.018UF 63V J
C795,796	KCFE1J823JBT	CAP , FILM	0.082UF 63V J
C797,798	KCFE1J332JBT	CAP , FILM	0.0033UF 63V J
C808	CCKT1H181KB	CAP , CERAMIC	180PF 50V KB
C809	HCEA1AH471T	CAP , ELECT	470UF 10V
C810,811	HCEA1CH101T	CAP , ELECT	100UF 16V
C812,852,857,874, 882,883	HCBS1H104ZFT	CAP , CERAMIC	0.1UF 50V Z
C813,814	HCEA1HH4R7T	CAP , ELECT	4.7UF 50V
C870,871	HCBS1H681KBT	CAP , CERAMIC	680PF 50V KB
C875~878	HCBS1H103ZFT	CAP , CERAMIC	0.01UF 50V Z
C880	HCEA1AH221T	CAP , ELECT	220UF 10V
C734,885	BCES0HD104	CAP , GOLD JP	EECS0HD104V
C853	KCKDKS472ME	CAP , CERAMIC(X1/Y2/SC)	0.0047UF/2.5KV
<i>Diodes</i>			
D701~703,705~716,718-722,729-754, 756-760	CVD30BSGATAAT	L.E.D , GREEN (TAPPING)	
D761,774,775,777,779	HVD1SS133MT	DIODE	1SS133T-77
D776	KVD1N4003ST	DIODE	1N4003
D778	KVD1N4003ST	DIODE	1N4003
D723	CVD50BOGDWGA	L.E.D , 2 COLOR	
<i>Transistors</i>			
Q701~703,705~716,718-722,724-729	HVTKRC107MT	T.R	KRC107M
Q734~737	HVTKTC2874BT	T.R , MUTE	KTC2874B

Reference Designator	Part Number	Description	
<i>Intergrated Circuits</i>			
IC72	BVIMB90F476APFG	IC , FLASH U-COM	FUJITSU
IC73	HRVRPM6938H4	SENSOR , REMOTE	RPM6938-H4
IC74	HVILC75725E	IC , VFL DRIVER	LC75725E
IC80	HVITC9215AF	I.C	TC9215AF
IC81,82,88	HVINJM2068MTE1	I.C , OP AMP	NJM2068M-TE1
IC83,84	HVI74ACT04SC	I.C , HEX INVERTER	74ACT04SC
IC86	HVINJM4556AMTE1	I.C , OP AMP	NJM4556AM-TE1
IC85	HVIRE5VT15CATZ	IC , RESET	RE5VT15CATZ
IC87	HVIRE5VL28CATZ	IC , RESET	RE5VL28CATZ
<i>Resistors</i>			
R701~703,705~716,718-722,826,827	CRD20TJ121T	RES , CARBON	120 OHM 1/5W J
R704,757,763	CRD20TJ332T	RES , CARBON	3.3K OHM 1/5W J
R730,833,834	CRD20TJ112T	RES,CABON	
R731,748,849,850,913	CRD20TJ223T	RES , CARBON	22K OHM 1/5W J
R732,847,848,853,854	CRD20TJ222T	RES , CARBON	2.2K OHM 1/5W J
R733,736,756,762,762,769,864,866	CRD20TJ272T	RES , CARBON	2.7K OHM 1/5W J
R734,735,744~747,771-773,875,881-891	CRD20TJ103T	RES , CARBON	10K OHM 1/5W J
R737,R892,R893	CRD20TJ100T	RES , CARBON	10 OHM 1/5W J
R753,759,766,865,903,904	CRD20TJ102T	RES , CARBON	1K OHM 1/5W J
R754,760,767,901,902	CRD20TJ152T	RES , CARBON	1.5K OHM 1/5W J
R755,761,768	CRD20TJ182T	RES , CARBON	1.8K OHM 1/5W J
R758,764,823,831,832,907,908, 918,919	CRD20TJ562T	RES , CARBON	5.6K OHM 1/5W J
R765	CRD20TJ752T	RES , CARBON	7.5K OHM 1/5W J
R775~800,802~806	CRD20TJ151T	RES , CARBON	150 OHM 1/5W J
R810,811,822,837,838,895-898	CRD20TJ101T	RES , CARBON	100 OHM 1/5W J
R813,814,839,840,845,846,871, 872,899,900,905,906	CRD20TJ104T	RES , CARBON	100K OHM 1/5W J
R824,873,874	CRD20TJ471T	RES , CARBON	470 OHM 1/5W J
R825	CRD20TJ181T	RES , CARBON	180 OHM 1/5W J
R829,830,835,836	CRD20TJ184T	RES , CARBON	180K OHM 1/5W J
R841,842,914~916	CRD20TJ473T	RES , CARBON	47K OHM 1/5W J
R843,844	CRD20TJ105T	RES , CARBON	1M OHM 1/5W J
R851,852	CRD20TJ392T	RES , CARBON	3.9K OHM 1/5W J
R855,856	CRD20TJ681T	RES , CARBON	680 OHM 1/5W J
R857,858,909~912	CRD20TJ221T	RES , CARBON	220 OHM 1/5W J
R868,894	CRD20TJ1R0T	RES , CARBON	1 OHM 1/5W J
R869,876~878	CRD20TJ750T	RES , CARBON	75 OHM 1/5W J
R875	CRD20TJ103T	RES , CARBON	10K OHM 1/5W J
R917	CRD20TJ123T	RES , CARBON	12K OHM 1/5W J
VR71	CVV2X05M104Z	RES , VARIABLE(BALANCE)	RK14128030214Y
VR72,73	CVV2X07C104Z	RES , VARIABLE(TONE)	RK14128030214C
<i>Miscellaneous</i>			
S701~721	CST1A012ZT	SW , TACT	SKHV10910G
SW01	HSH1A008ZV	SW , PUSH (MOMS)	
BN10	CWZAVR125BN10	WIRE ASS'Y (SHIELD)	
BN16	CWZAVR2550BN16	WIRE ASS'Y (SHIELD)	
BN18	CWZAVR125BN18	WIRE ASS'Y (SHIELD)	

Reference Designator	Part Number	Description	
BN41	CWZAVR125BN41	WIRE ASS'Y (SHIELD)	
BN80	CWB2B908320EW	WIRE ASS'Y	
BN81	CWB2B906250BM	WIRE ASS'Y	
BN83	CWB1C902250BM	WIRE ASS'Y	
BN84	CWB2B905100EN	WIRE ASS'Y	
BN85,90	CWB2B902090EN	WIRE ASS'Y	
BN87	CWZAVR2550BN87	WIRE ASS'Y (SHIELD)	
BN88	CWB2B904070EN	WIRE ASS'Y	
BN89	CWB2B905080EN	WIRE ASS'Y	
BN94	KJP10GB99ZM	WAFER	MOLEX35237-1010
BN95	KJP08GB99ZM	CONNECTOR , HOUSING	MOLEX35237-0810
CN10	KJP04GB46ZM	WAFER	MOLEX 53015
CN11	KJP09GA98ZM	WAFER	MOLEX35336-0910
CN12	KJP14GA98ZM	WAFER	MOLEX35336-1410
CN16	KJP08GB46ZM	WAFER	MOLEX 53015
CN72	KJP32GA117ZG	WAFER , CARD CABLE	GF102-32S-TS
CN82	KJP06HA37ZM	WAFER	MOLEX42140-2206
CN84,89	KJP05GA19ZM	WAFER	MOLEX53014-0510
CN85,90	KJP02GA19ZM	WAFER	MOLEX53014-0210
CN86	KJP02GA89ZM	WAFER	MOLEX35328-02
CN87	KJP06GA19ZM	WAFER	MOLEX53014-0610
CN88	KJP04GA19ZM	WAFER	MOLEX53014-0410
FIP1	HFLCM2054C	F.I.P (DISPLAY)	
JK81	CJJ4M041Z	JACK , BOARD (COAX)	
JK82	HJSTORX179	MODULE,OPTICAL(RECEIVE)	TORX179
JK83	HJJ2E026Z	JACK , HEADPHONE(SIVER PLATE)	
JK85	CJJ9M003Z	JACK , S-VIDEO	
JK86	CJJ4S023Z	JACK , BOARD	
JW82	CWZAVR2550JW82	WIRE , ASS'Y	
JW83	CWE8202150RV	WIRE ASS'Y	
JW84	CWE8202110RV	WIRE, ASS'Y	
VR74	HSR2A023Z	VR , ENCODER	
X701	HOX04194E120C	CRYSTAL	
L702	HLQ02C100KT	COIL , AXAIL	

**PCB , MAIN***Capacitors*

C501~505	HCEA1VH100T	CAP , ELECT	10UF 35V
C506~510	CCKT1H331KB	CAP , CERAMIC	330PF 50V KB
C561~565,907	HCEA1CH101T	CAP , ELECT	100UF 16V
C566~570	HCEA1EH470T	CAP , ELECT	47UF 25V
C571~575	CCKT1H681KB	CAP , CERAMIC	680PF 50V KB
C601~605	CCCT1H120JC	CAP , CERAMIC	12PF 50V JC
C606~610	CCCT1H330JC	CAP , CERAMIC	33PF 50V JC
C641~645,681~685	HCEA1HH100T	CAP , ELECT	10UF 50V
C826	HCQI1H182JZT	CAP , MYLAR	1800PF 50V J
C901,998	CCFT1H104ZF	CAP , SEMI	0.1UF 50V ZF
C905,908,923,925,963,999	CCKT1H223ZF	CAP , CERAMIC	0.022UF 50V ZF
C911	HCEA1CH471T	CAP , ELECT	470UF 16V
C912	HCEA1CH221T	CAP , ELECT	220UF 16V
C922,924,962	HCEA1EH101T	CAP , ELECT	100UF 25V
C938,991	HCEA1HH1R0T	CAP , ELECT	1UF 50V
C939	HCEA1HH4R7T	CAP , ELECT	4.7UF 50V
C940	HCEA1AH471T	CAP , ELECT	470UF 10V
C971~975	HCQI1H562JZT	CAP , MYLAR	5600PF 50V J
C976~979,993~997	HCQI1H473JZT	CAP , MYLAR	0.047UF 50V J
C631~640	HCEA1JH221E	CAP , ELECT	220UF 63V
C903	BCQE2E104KDE	CAP , LINE ACROSS	0.1UF 250V KD

Reference Designator	Part Number	Description		
C904	KCKDKS472ME	CAP , CERAMIC(X1/Y2/SC)		0.0047UF/2.5KV
C906	HCEA1EH102E	CAP , ELECT		1000UF 25V
C915,916	HCET63VFHS123ND	CAP , ELECT		12000UF 63V
C917	HCEA1EH332E	CAP , ELECT		3300UF 25V
C918	HCEA1EH222E	CAP , ELECT		2200UF 25V
C961	HCEA1CH472E	CAP , ELECT		4700UF 16V
<i>Diodes</i>				
D501~505,581~585,902,911,912, 914-916,953-955	HVD1SS133MT	DIODE		1SS133T-77
D901,903~906,961-963	KVD1N4003ST	DIODE		1N4003
D956	KVD1N4003SRT	DIODE	TW	1N4003
<i>Transistors</i>				
Q501~505,601~605	HVTKTA1268GRT	T.R		KTA1268GR
Q511~520,556~565	HVTKTC3200GRT	T.R		KTC3200GR
Q541~545	HVTKTC3198YT	T.R		KTC3198Y
Q611~615	HVTKTD600KGR	T.R , BIAS		KTD600KGR
Q621~625	HVT2SA1360O	T.R		2SA1360O
Q626~630	HVT2SC3423O	T.R		2SC3423O
Q652~655,661	BVT2SB1560	T.R , POWER		2SB1560
Q657~660,670	BVT2SD2390	T.R , POWER		2SD2390
Q681~685,901,942,943	KVTKSC2785YT	T.R		KSC2785Y
Q806,969~973	HVTKTC2874BT	T.R , MUTE		KTC2874B
Q938,939,952,992	HVTKRA107MT	T.R		KRA107M
Q951,960,991	HVTKRC107MT	T.R		KRC107M
Q961	HVTKTA1024YT	T.R		KTA1024Y
<i>Intergrated Circuits</i>				
IC91	HVIMC7815C	I.C, REGULATOR		KA7815-ABTU
IC92	HVIMC7915C	I.C, REGULATOR		KA7915-ABTU
IC93,94	HVIMC7805C	I.C, REGULATOR		KA7805-ABTU
<i>Resistors</i>				
R501~505	CRD20TJ433T	RES , CARBON		43K OHM 1/5W J
R506~510	CRD20TJ333T	RES , CARBON		33K OHM 1/5W J
R511~520,940	CRD20TJ152T	RES , CARBON		1.5K OHM 1/5W J
R521~525,806,974-978	CRD20TJ471T	RES , CARBON		470 OHM 1/5W J
R527~530,621~626	CRD20TJ750T	RES , CARBON		75 OHM 1/5W J
R531~540	CRD20TJ221T	RES , CARBON		220 OHM 1/5W J
R541~545	CRD20TJ271T	RES , CARBON		270 OHM 1/5W J
R556~560,962	CRD20TJ273T	RES , CARBON		27K OHM 1/5W J
R561~565,678~680	CRD20TJ182T	RES , CARBON		1.8K OHM 1/5W J
R566~575,581~600,987	CRD20TJ561T	RES , CARBON		560 OHM 1/5W J
R576~580	CRD20TJ100T	RES , CARBON		10 OHM 1/5W J
R601~610,941~943,945	CRD20TJ223T	RES , CARBON		22K OHM 1/5W J
R611~615,961	CRD20TJ331T	RES , CARBON		330 OHM 1/5W J
R616~620	CRD20TJ122T	RES , CARBON		1.2K OHM 1/5W J
R631~640	KRD25FJ180T	RES , CARBON		18 OHM 1/4W J
R646~655	KRD25FJ3R3T	RES , CARBON		3.3 OHM 1/4W J
R666~670,696~700	CRD25TJ470T	RES , CARBON		47 OHM 1/4W J



Reference Designator	Part Number	Description	
R671~675	CRD20TJ911T	RES , CARBON	910 OHM 1/5W J
R676,677	CRD25TJ182T	RES , CARBON	1.8K OHM 1/4W J
R681~685,960,992	CRD20TJ562T	RES , CARBON	5.6K OHM 1/5W J
R686~690,930,932,966,998	CRD20TJ103T	RES , CARBON	10K OHM 1/5W J
R816,939,969~973	CRD20TJ472T	RES , CARBON	4.7K OHM 1/5W J
R826,979~983	CRD20TJ473T	RES , CARBON	47K OHM 1/5W J
R910,963	CRD20TJ105T	RES , CARBON	1M OHM 1/5W J
R911	CRD20TJ820T	RES , CARBON	82 OHM 1/5W J
R913,914	CRD20TJ153T	RES , CARBON	15K OHM 1/5W J
R917~920	CRD25TJ393T	RES , CARBON	39K OHM 1/4W J
R944	CRD25TJ223T	RES , CARBON	22K OHM 1/4W J
R986	CRD20TJ102T	RES , CARBON	1K OHM 1/5W J
R988	CRD20TJ303T	RES , CARBON	30K OHM 1/5W J
R991	CRD20TJ822T	RES , CARBON	8.2K OHM 1/5W J
R656~660	KRF5EKR22HX2	RES , CEMENT(*2)	0.22/5W *2
R904	BRDERC12UGK335T	RES , CARBON JP	3.3M OHM 1/2W
R905,993~997	KRG1ANJ100H	RES , METAL OXIDE FILM	10 OHM 1W J
VR61~65	HVN1RA221B01T	RES , SEMI FIXED(220 OHM)	RH0615C100221

*Miscellaneous*

BN20	CWB3FB03280UP	WIRE ASS'Y	
BN90	CWB4D232450PU	WIRE ASS'Y	
JW91	CWE8212230VV	WIRE ASS'Y	
JW92	CWEE212120VV	WIRE ASS'Y	
CN61~65	KJP03GA01ZM	WAFER	MOLEX 5267-03A
CN80	KJP08GA19ZM	WAFER	MOLEX53014-0810
CN91	KJP02KA060ZY	WAFER	7.92MM(YUNHO)
CN92	KJP02GA89ZM	WAFER	MOLEX35328-02
CN94	KJP10GA98ZM	WAFER	MOLEX35336-1010
CN95	KJP08GA98ZM	WAFER	MOLEX35336-0810
CN96	KJP07GA01ZM	WAFER	MOLEX 5267-07A
JK91	CJJ5N009Z	TERMINAL , SPEAKER	
JK92	CJJ5Q011Z	TERMINAL , SPEAKER	
JK93	CJJ4M040Z	JACK , BOARD (SW)	
L501~505	CLEY0R5KAK	COIL , SPEAKER	0.5UH K
OL91	KJJ7A015Z	OUTLET , AC(UL/2P/SEP)	A204D0041P
RY94	HSL1A008ZE	RELAY	SDT-S-112DMR
TH91	KRTP42T7D330B	THERMAL SENSOR , POSISTOR	P42T7D330BW20
T902	CLT5J033ZU	TRANS , SUB	SR-68

**PCB , INPUT***Capacitors*

C201~206,211~224,321,322,325,326	CCKT1H221KB	CAP , CERAMIC	220PF 50V KB
C231~236,349,350,799,382~386,390, 421,426,440,447,452,454,456,708,709, 712,728,731,733,752,754,780,783	HCEA1CH101T	CAP , ELECT	100UF 16V
C237,240,359,361,362,387,703,705	CCKT1H181KB	CAP , CERAMIC	180PF 50V KB
C238,239,335,360	CCKT1H471KB	CAP , CERAMIC	470PF 50V KB
C261~272	HCEA1EH220T	CAP , ELECT	22UF 50V
C273~284	HCQI1H332JZT	CAP , MYLAR	3300PF 50V J
C285,286,288~292,294-296,333	CCKT1H561KB	CAP , CERAMIC	560PF 50V KB
C287,293,371	HCQI1H182JZT	CAP , MYLAR	1800PF 50V J

Reference Designator	Part Number	Description	
C297~302,323,324,327,328,334,347, 348,358,420,430,439,446,449,460, 730,766	HCBS1H223ZFT	CAP , CERAMIC	0.022UF 50V Z
C303~308	HCEA1HH220T	CAP , ELECT	22UF 50V
C336,357,461,735,921	CCKT1H223ZF	CAP , CERAMIC	0.022UF 50V ZF
C339,340,772	HCBS1H103ZFT	CAP , CERAMIC	0.01UF 50V Z
C343~346,351~356,363~368,375~380, 412,416,419,425,433,435,438,441,443, 445,448,453,455,762,769	HCEA1VH100T	CAP , ELECT	10UF 35V
C372~374	CCKT1H151KB	CAP , CERAMIC	150PF 50V KB
C388,389	HCEA1CH471T	CAP , ELECT	
C391,719,720,727,729,732,736,740,743, 744,746,747,751,763,768,779,786,787	HCBS1H104ZFT	CAP , CERAMIC	0.1UF 50V Z
C395	HCEA1HH1R0T	CAP , ELECT	1UF 50V
C418,431,442,444,458,726,776	CCKT1H101KB	CAP , CERAMIC	100PF 50V KB
C457,721,737	HCBS1H101KBT	CAP , CERAMIC	100PF 50V K
C701,702,781,784	HCEA1AH471T	CAP , ELECT	470UF 10V
C393,704,706,707,734,755,756,761,773, 774,901,902	CCFT1H104ZF	CAP , SEMI	0.1UF 50V ZF
C710,778,785	CCKT1H473ZF	CAP , CERAMIC	0.047UF 50V ZF
C711,713,714,716~718	CCCT1H270JC	CAP , CERAMIC	22PF 50V JC
C715,782	HCBS1H473ZFT	CAP , CERAMIC	0.047UF 50V Z
C722,723	CCCT1H100DC	CAP , CERAMIC	10PF 50V DC
C724	HCBS1H330JT	CAP , CERAMIC	
C725	CCCT1H330JC	CAP , CERAMIC	33PF 50V JC
C392,741,742	HCEA1EH470T	CAP , ELECT	47UF 25V
C745,770	HCEA1HH2R2T	CAP , ELECT	2.2UF 50V
C764,765	CCCT1H120JC	CAP , CERAMIC	12PF 50V JC
C771	HCBS1H471KBT	CAP , CERAMIC	470PF 50V KB
C775	CCKT1H102KB	CAP , CERAMIC	1000PF 50V KB
C777	HCEA0JH102T	CAP , ELECT	1000UF 6.3V
C903~906,908,910,913	CCKT1H103ZF	CAP , CERAMIC	0.01UF 50V ZF
C907,909,914	HCEA1HH470T	CAP , ELECT	47UF 50V
C911	HCEA1HH4R7T	CAP , ELECT	4.7UF 50V
C912	HCEA1HH101T	CAP , ELECT	100UF 50V
C915,916	HCQI1H104JZT	CAP , MYLAR	0.1UF 50V J
C917,918	HCQI1H103JZT	CAP , MYLAR	0.01UF 50V J
C919,920	HCQI1H473JZT	CAP , MYLAR	0.047UF 50V J
C922	HCEA1EH101T	CAP , ELECT	100UF 25V
C923	HCEA1CH332E	CAP , ELECT	3300UF 16V

*Diodes*

D418	HVDMTZJ5.6BT	DIODE , ZENER	5.6V 1/2W
D701	HVDMTZJ4.7BT	DIODE , ZENER	4.7V 1/2W
D702	HVDMTZJ3.3BT	DIODE , ZENER	3.3V 1/2W
D901~906	KVD1N4003SRT	DIODE	TW 1N4003
D907,910	HVDMTZJ15BT	DIODE , ZENER	15V 1/2W
D908	HVDMTZJ6.2BT	DIODE , ZENER	6.2V 1/2W
D909	HVDKBU804F	DIODE , BRIDGE	KBU804F

*Transistors*

Q301	HVTKTD1302T	T.R	KTD1302
------	-------------	-----	---------

Reference Designator	Part Number		Description
Q302,902	HVTKRA107MT	T.R	KRA107M
Q395,396	HVTKTC2874BT	T.R , MUTE	KTC2874B
Q701,702	HVTKSC2316YT	T.R	KSC2316Y
Q901,903	HVTKTA1271YT	T.R	KTA1271Y
Q904	HVTKRC107MT	T.R	KRC107M
Q455	HVTKSA614Y	T.R	KSA614Y
<i>Intergrated Circuits</i>			
IC20	HVITC9163AF	I.C , FUNCTION	TC9163AF
IC21,23~29,32~34	HVINJM2068MTE1	I.C , OP AMP	NJM2068M-TE1
IC22	HVITC9164AF	I.C , FUNCTION	TC9164AF
IC30	HVITC9162AF	I.C , FUNCTION	TC9162AF
IC31	HVITC9482F	I.C , ELECT VOL	TC9482F
IC41,43,44	HVINJM2296M	I.C , VIDEO SW	NJM2296M
IC71,72	HVITC74HCU04AFN	IC , INVERTER	TC74HCU04AFN
IC75	HVIAK4114VQ	IC , DIR	AK4114VQ
IC77	HVIAK5380VT	I.C 2CH AUDIO ADC	AK5380VT
IC78	HVIAK4356VQ	I.C , D/A CONVERTER	AK4356VQ
IC79	HVICS493263-CLG	I.C , DSP HK	CS493263-CLG
IC95	HC3990509F	I.C, REGULATOR	NJM7905FA
<i>Resistors</i>			
R201~206,211~223,477,720,771	CRD20TJ471T	RES , CARBON	470 OHM 1/5W J
R224	CRD20TJ272T	RES , CARBON	2.7K OHM 1/5W J
R225~230,235~247	CRD20TJ474T	RES , CARBON	470K OHM 1/5W J
R262,263,353~358,365~367,377~379	CRD20TJ184T	RES , CARBON	180K OHM 1/5W J
R250~255,307~312,329~332,338,339, 347,348,351,352,371,389,383~387,708, 712,715,726,749,753,769	CRD20TJ101T	RES , CARBON	100 OHM 1/5W J
R256~261,359~362,364,369,746,747	CRD20TJ472T	RES , CARBON	4.7K OHM 1/5W J
R271~274,277~282	CRD20TJ392T	RES , CARBON	
R275,276,413,414,421 427,432,445,446 450~452,458,461,463 465,468,729,752,914	CRD20TJ102T	RES , CARBON	1K OHM 1/5W J
R283~288,295~300,340,343~346, 374~376,396,397	CRD20TJ562T	RES , CARBON	5.6K OHM 1/5W J
R289~294,301~306,908	CRD20TJ122T	RES , CARBON	1.2K OHM 1/5W J
R313~318,713,714,716~719	CRD20TJ104T	RES , CARBON	100K OHM 1/5W J
R321~328,333~335,426,440,460,462, 472,475,750,751,765,767	CRD20TJ332T	RES , CARBON	3.3K OHM 1/5W J
R336	CRD20TJ123T	RES , CARBON	12K OHM 1/5W J
R337,911	CRD20TJ153T	RES , CARBON	15K OHM 1/5W J
R341,395,723	CRD20TJ105T	RES , CARBON	1M OHM 1/5W J
R349,350	CRD20TJ151T	RES , CARBON	150 OHM 1/5W J
R363	CRD25TJ101T	RES , CARBON	100 OHM 1/4W J
R368,370,380~382,388	CRD20TJ683T	RES , CARBON	68K OHM 1/5W J
R248,373,701,704,748,754~762,766,773	CRD20TJ103T	RES , CARBON	10K OHM 1/5W J
R391~394	CRD20TJ112T	RES,CABON	1.1K OHM 1/5W J

Reference Designator	Part Number	Description	
R419,425,431,436,437,453,454,456,457, 464,467,470,471,473,474,705~707,709	CRD20TJ750T	RES , CARBON	75 OHM 1/5W J
R422,455,459,702,703,710,711,722,724, 736,774,775	CRD20TJ1R0T	RES , CARBON	1 OHM 1/5W J
R433,466,469,906	CRD20TJ100T	RES , CARBON	10 OHM 1/5W J
R725	CRD20TJ183T	RES , CARBON	18K OHM 1/5W J
R727,728,772	CRD20TJ4R7T	RES , CARBON	4.7 OHM 1/5W J
R730	CRD20TJ121T	RES , CARBON	120 OHM 1/5W J
R737	CRD25TJ2R7T	RES , CARBON	2.7 OHM 1/4W J
R740~745,764,768,777	CRD20TJ330T	RES , CARBON	33 OHM 1/5W J
R763	CRD20TJ333T	RES , CARBON	33K OHM 1/5W J
R770	CRD20TJ182T	RES , CARBON	1.8K OHM 1/5W J
R776	CRD25TJ1R0T	RES , CARBON	1 OHM 1/4W J
R778,905,907	CRD20TJ8R2T	RES , CARBON	8.2 OHM 1/5W J
R909,913	CRD20TJ473T	RES , CARBON	47K OHM 1/5W J
R912	CRD20TJ154T	RES , CARBON	150K OHM 1/5W J
R319	KRG2ANJ470H	RES , METAL OXIDE FILM	47 OHM 2W J
R901~904	KRQ1AJR47H	RES , FUSE	0.47 OHM 1W J

*Miscellaneous*

BN21	CWB1E908060MM	WIRE ASS'Y	
BN96	CWB1C907200BM	WIRE ASS'Y	
BN97	CWB1C903080BM	WIRE ASS'Y	
JW21,22	CWE6202070AA	WIRE ASS'Y	
JW23	CWE7202110AA	WIRE ASS'Y	
JW24	CWED202100RV	WIRE ASS'Y	
JW71	CWE7202090AA	WIRE ASS'Y	
BN11	KJP09GB99ZM	CONNECTOR	MOLEX35237-0910
BN12	KJP14GB99ZM	WAFER	MOLEX35237-1410
CN13	KJP13GA115ZG	WAFER, CARD CABLE	GF120-13S-TS
CN15,43	KJP09GA115ZG	WAFER , CARDCABLE	
CN18	KJP05GA19ZM	WAFER	
CN20	KJP03GA90ZM	WAFER	MOLEX35313-0310
CN41	KJP06GA19ZM	WAFER	
CN72	KJP32GA117ZG	WAFER , CARD CABLE	GF102-32S-TS
CN81	KJP06GA01ZM	WAFER	MOLEX 5267-06A
CN83	KJP02GA01ZM	WAFER	MOLEX 5267-02A
CN97	KJP03GA01ZM	WAFER	MOLEX 5267-03A
L705	KLQ100J405T	COIL, PEAKING(RADIAL)	10UH J 4X5
L703,706,707,709	KLZ9H001Z	BEAD , CORE	
JK21	CJJ4R019Z	JACK , IN/OUT	
JK23,24	CJJ4P014Y	JACK , IN/OUT	
JK25	CJJ4R034Z	JACK , IN/OUT	
JK26,27	HJSTORX179	MODULE,OPTICAL(RECEIVE)	TORX179
JK28	HJS9L001Z	MODULE, OPTICAL	TOTX178
JK29	CJJ4S022Z	JACK , BOARD	
JK42	HJJ9N001Z	JACK , S-VIDEO(2P/H)	JY-5036-040
JK43	HJJ9S001Z	JACK , S-VIDEO(3P/H)	JY-5041-040
JK49	CJJ4N043Z	JACK , BOARD	
JK50	CJJ4S010Z	JACK , BOARD	
X701	HOX12288E320C	CRYSTAL	
F900,901	KBA2C2500TLU	FUSE (2.5A 250V)	
F902	KBA2C6300TLU	FUSE (6.3A 250V)	
F903,904	KBA2C8000TLU	FUSE (8A 250V)	
CB13	CWC1C4A13B080B	CABLE , CARD 80mm 13P	
CB15	CWC1C4A09B130B	CABLE , CARD 130mm 8P	

Reference Designator	Part Number	Description	
CB72	CWC1B2A32A210B	CABLE , CARD	
<b>CHASSIS MISCELLANEOUS</b>			
T901	CLT5V030ZU	TRANS , POWER	
TUNER MODULE	CNVKSTM9014MS07	TUNER MODULE	KSTM9014MS07
	CLZ9W003Z	FERRITE , RING	



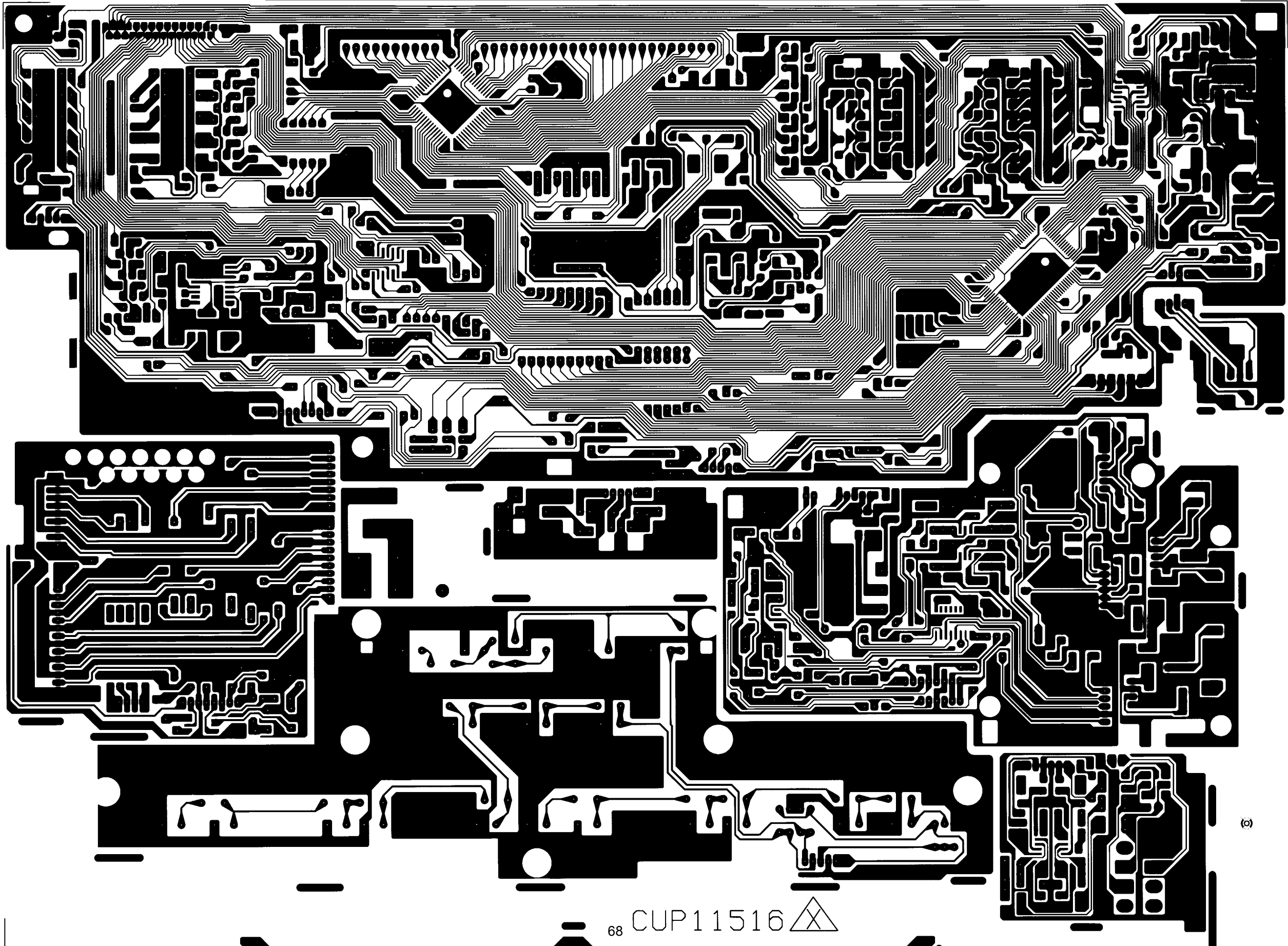

CUP11516-1

AVM02V0

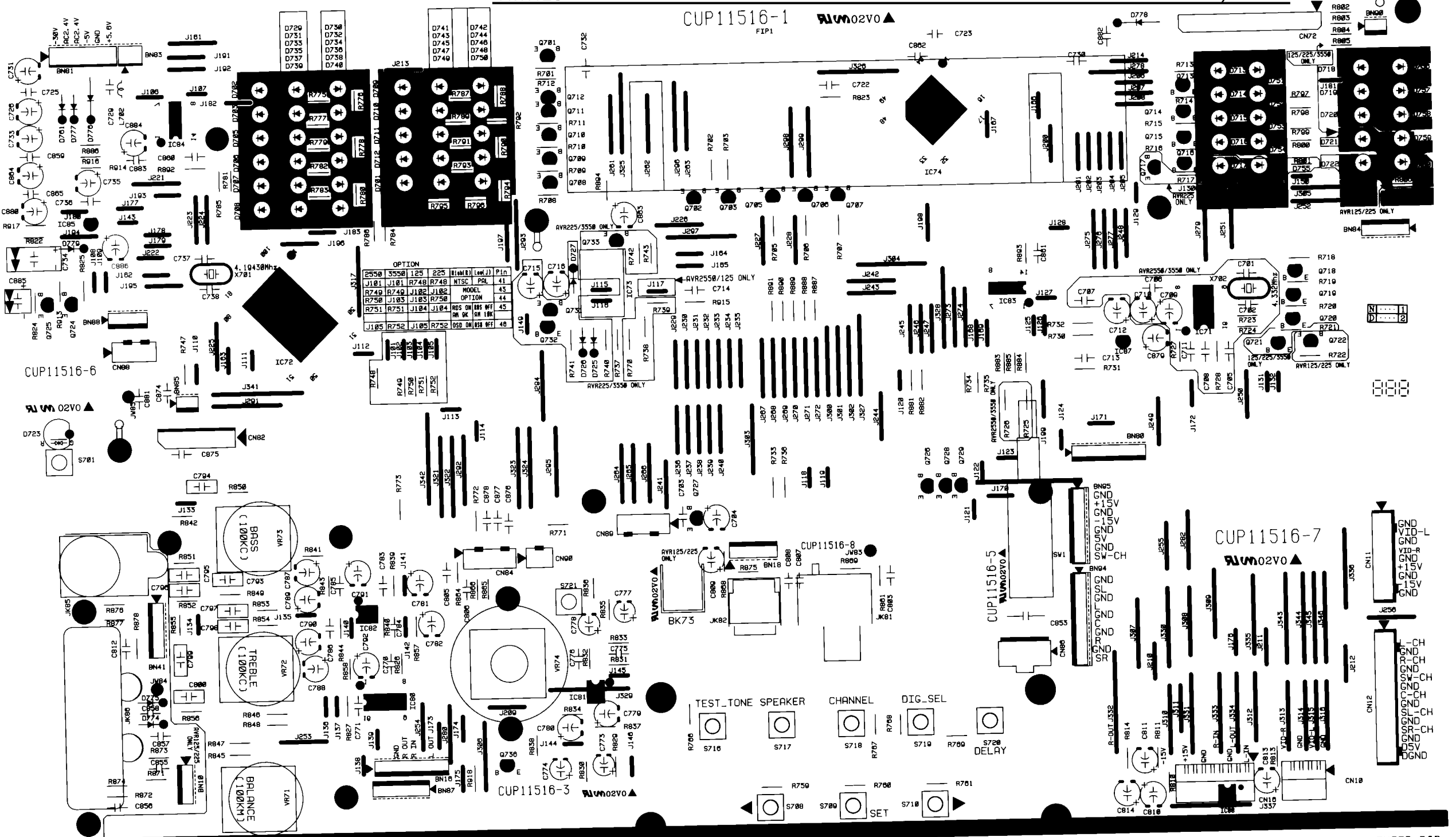

CUP11516-6

CUP11516-7

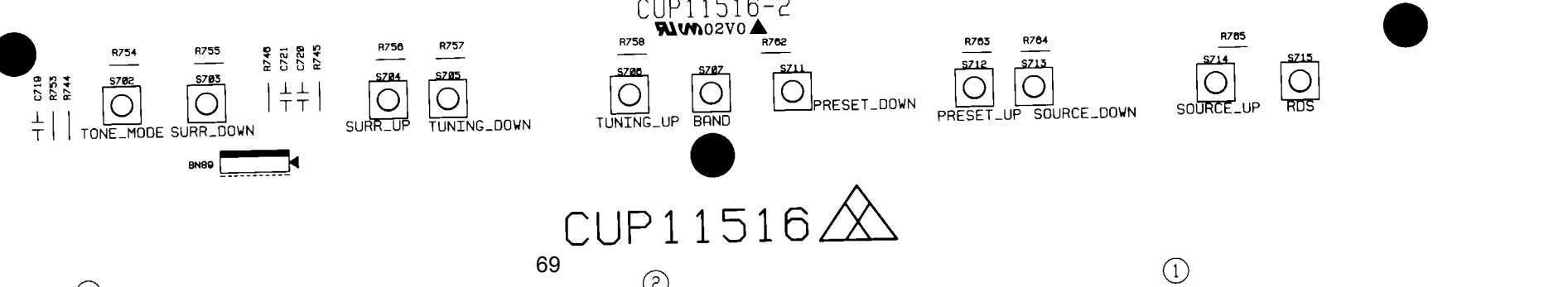
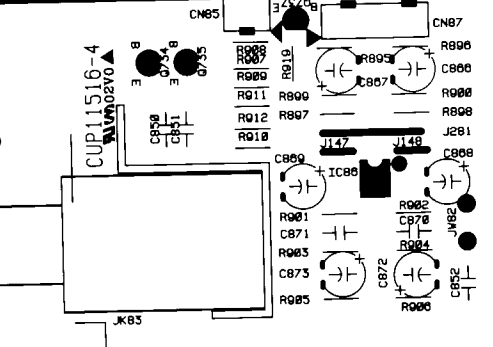



CUP11516

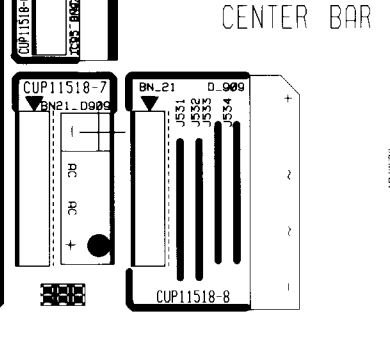
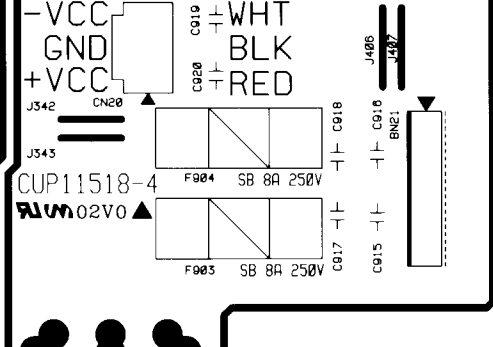
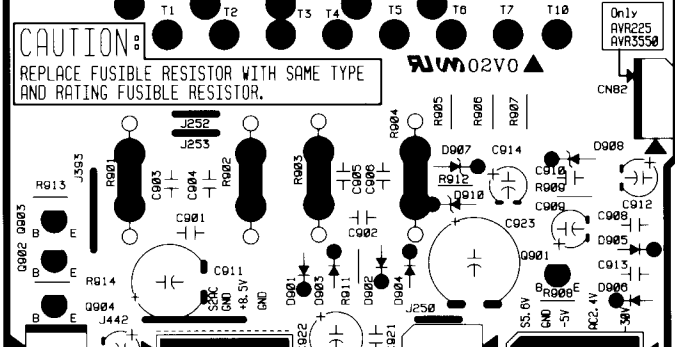
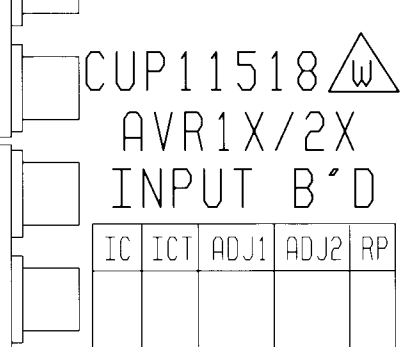
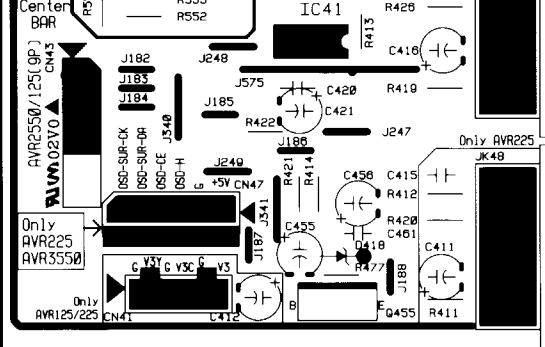
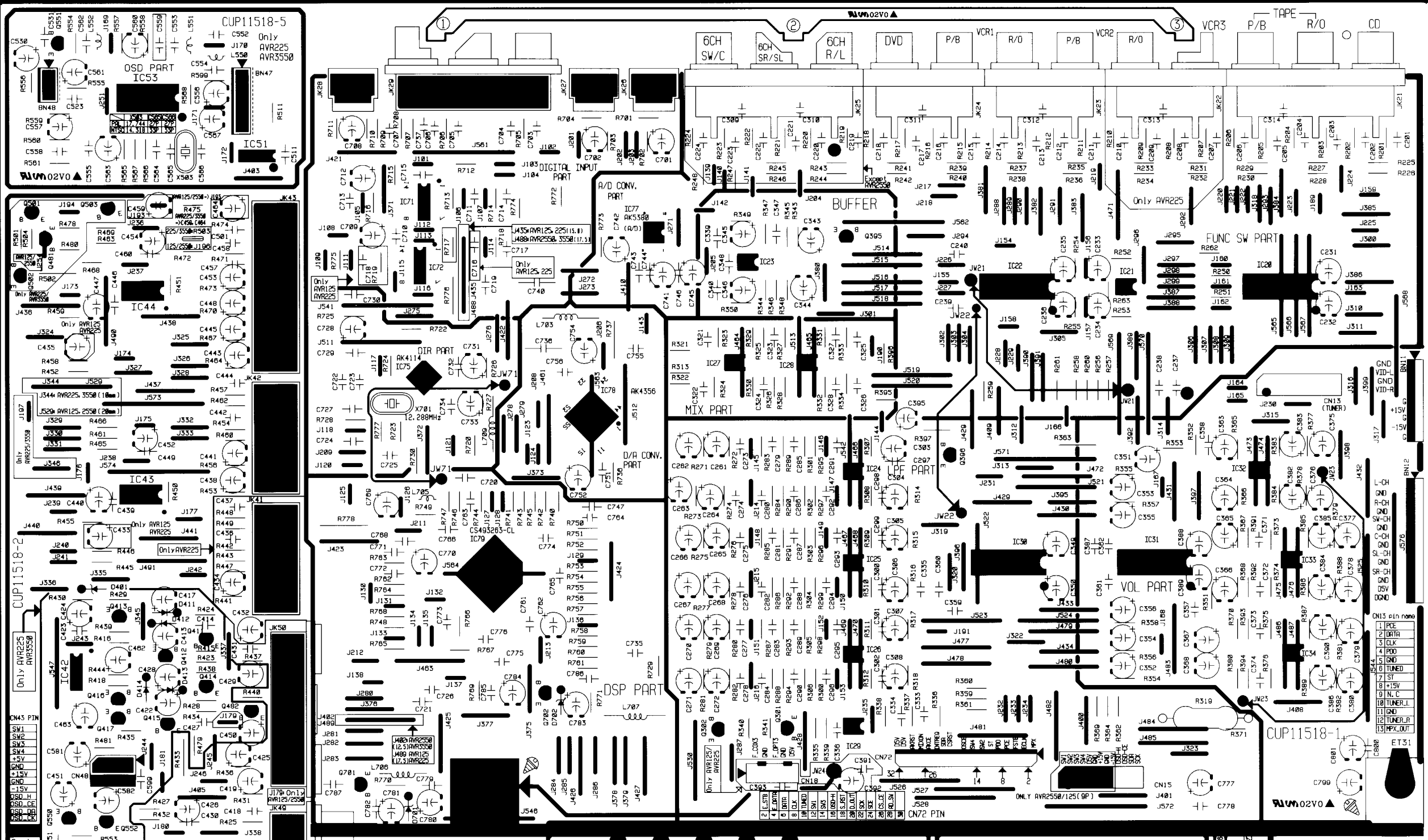

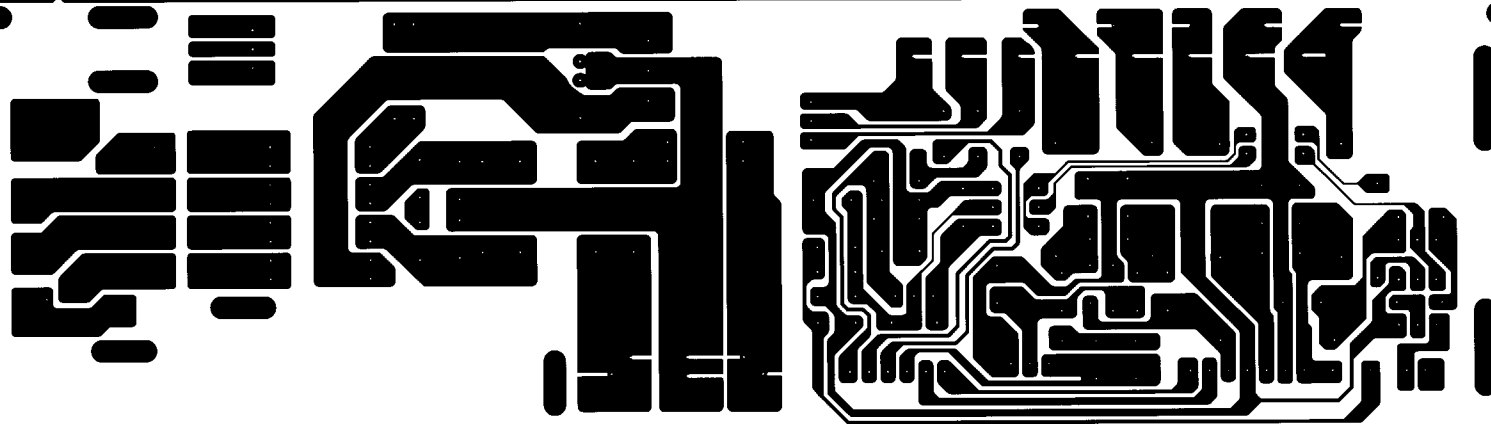
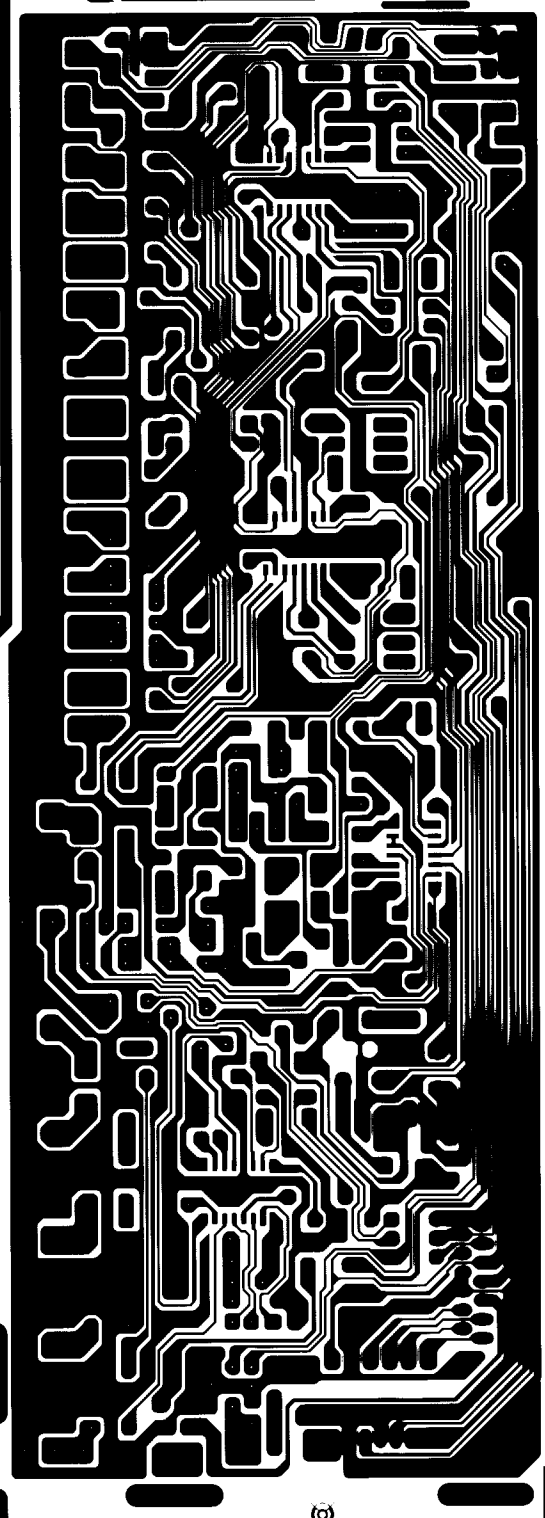
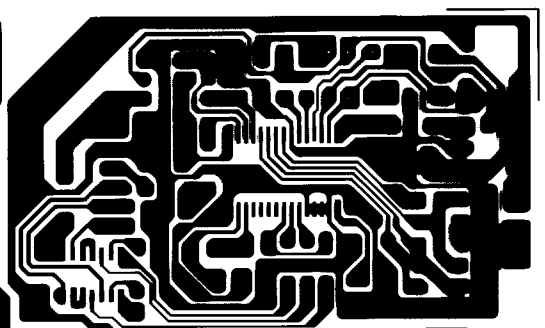
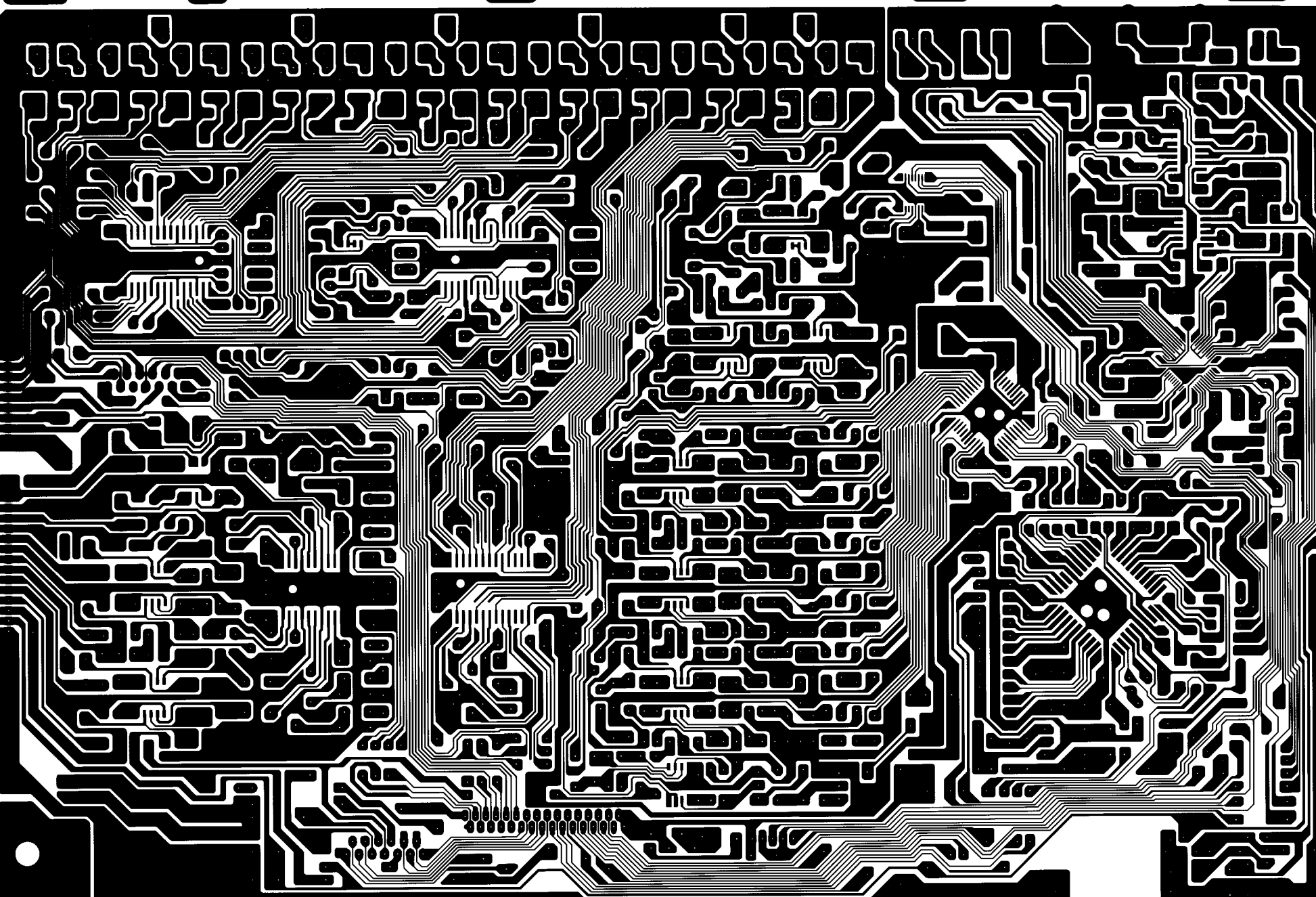

(c)





CUP11518 

(c)

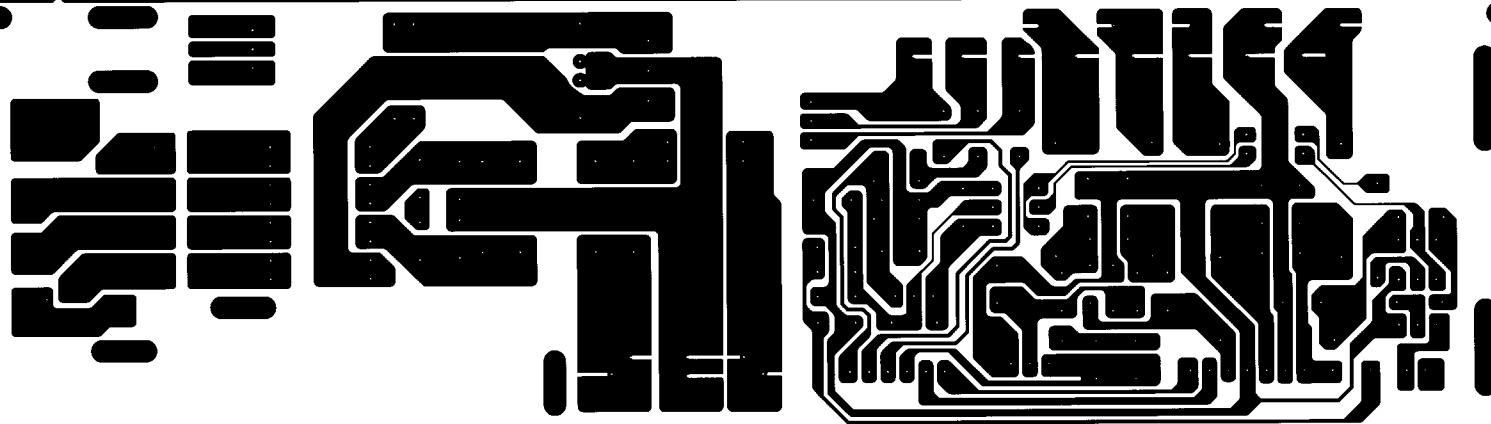
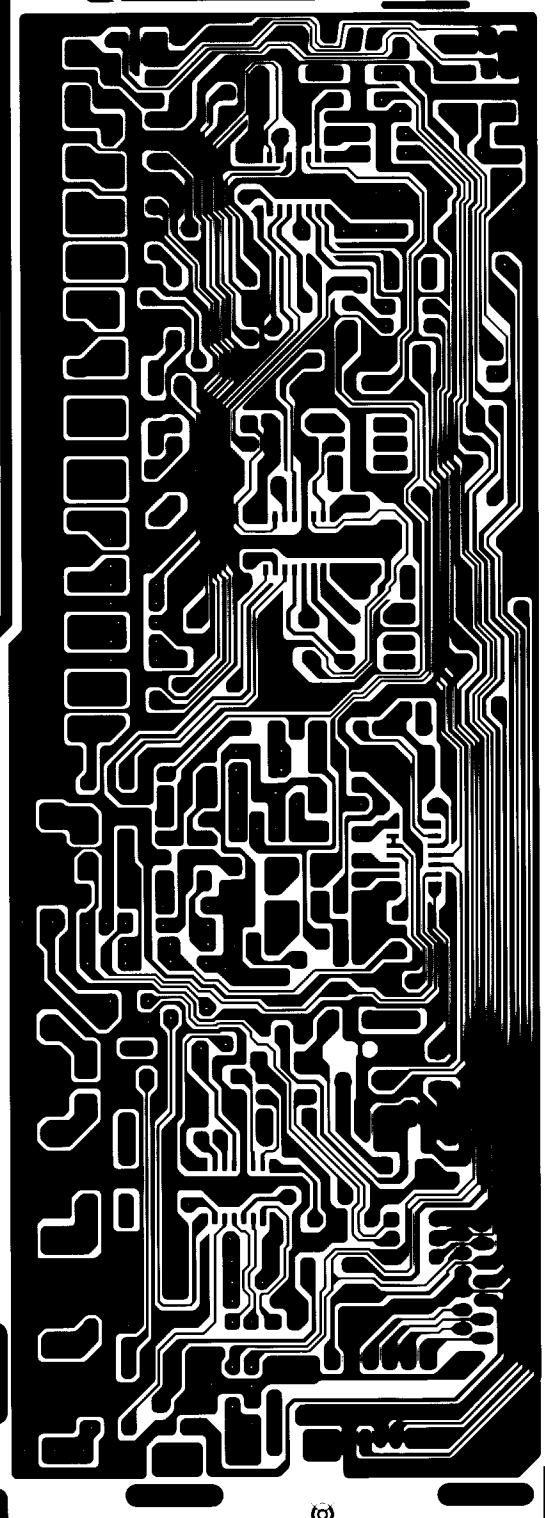
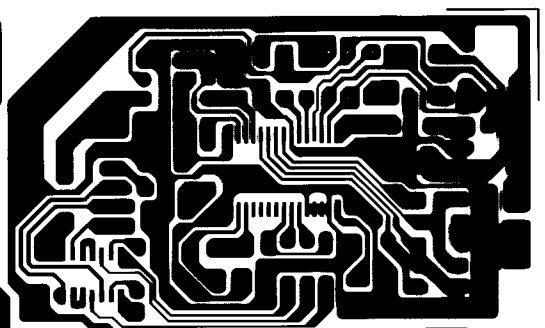
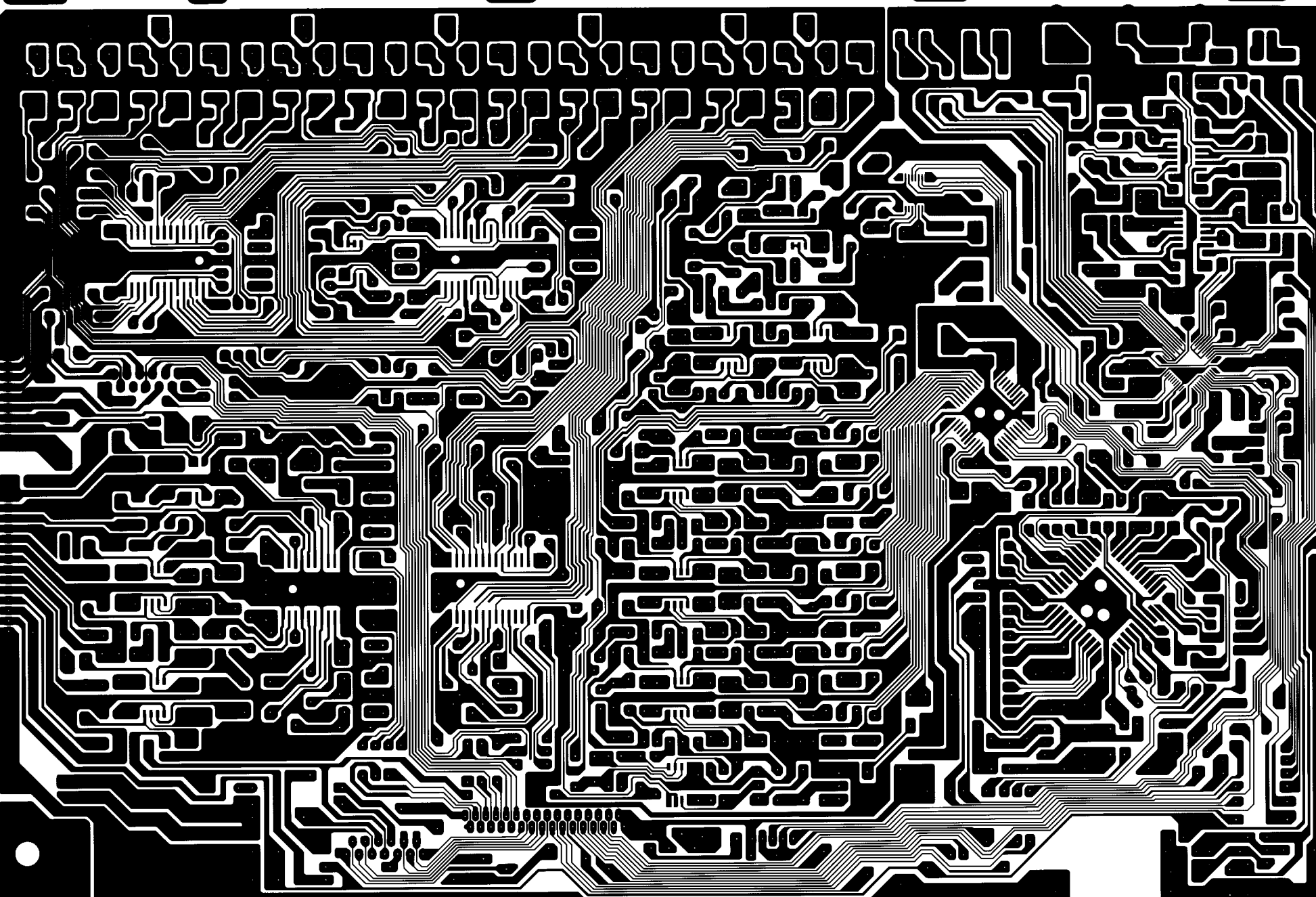

(c)



CUP11518 

(c)

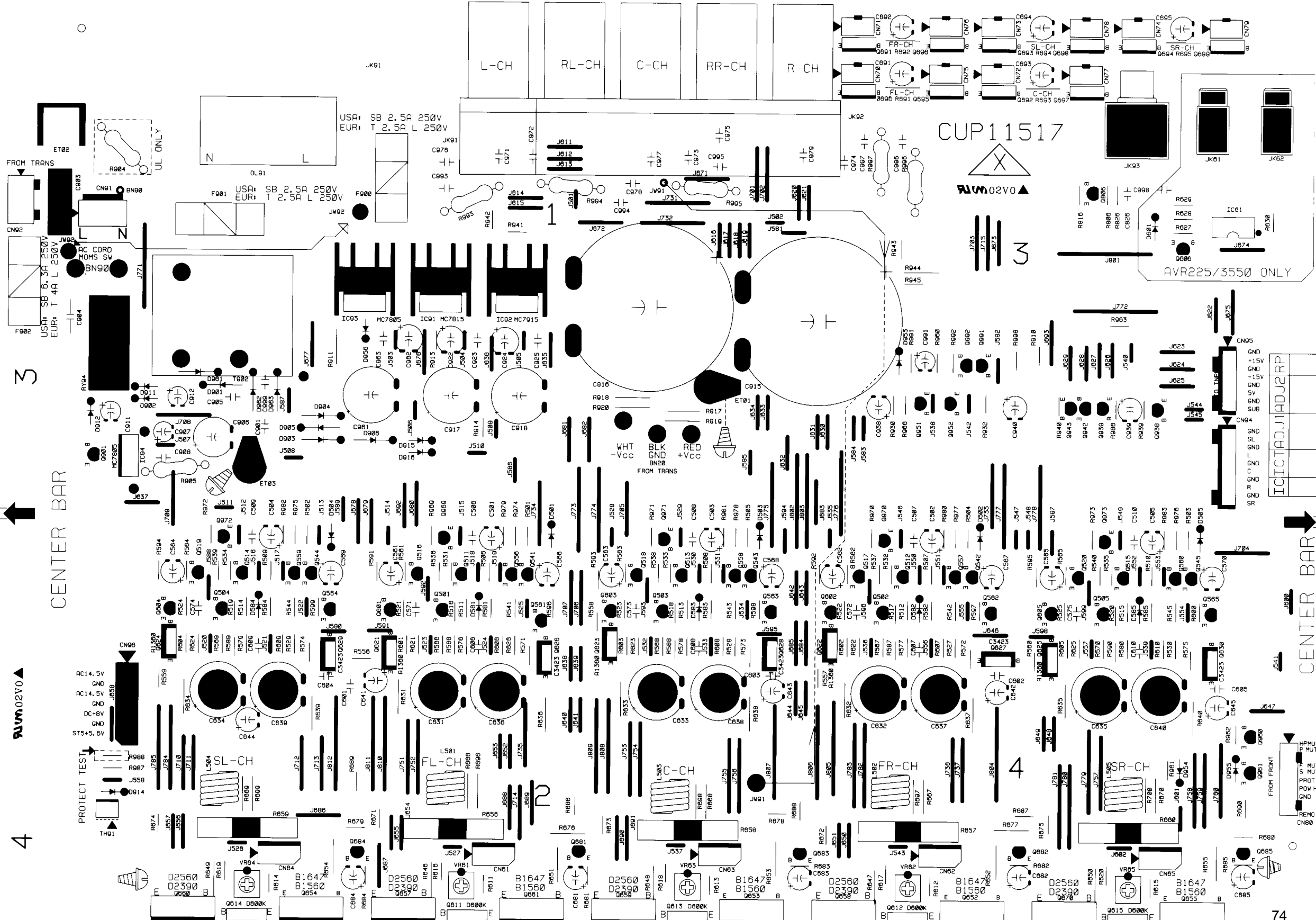

CUP11517

AVM02V0

AVR225/3550 ONLY

ICICTADJ1ADJ2IRP

CENTER BAR

FROM FRONT

3

4

3

4

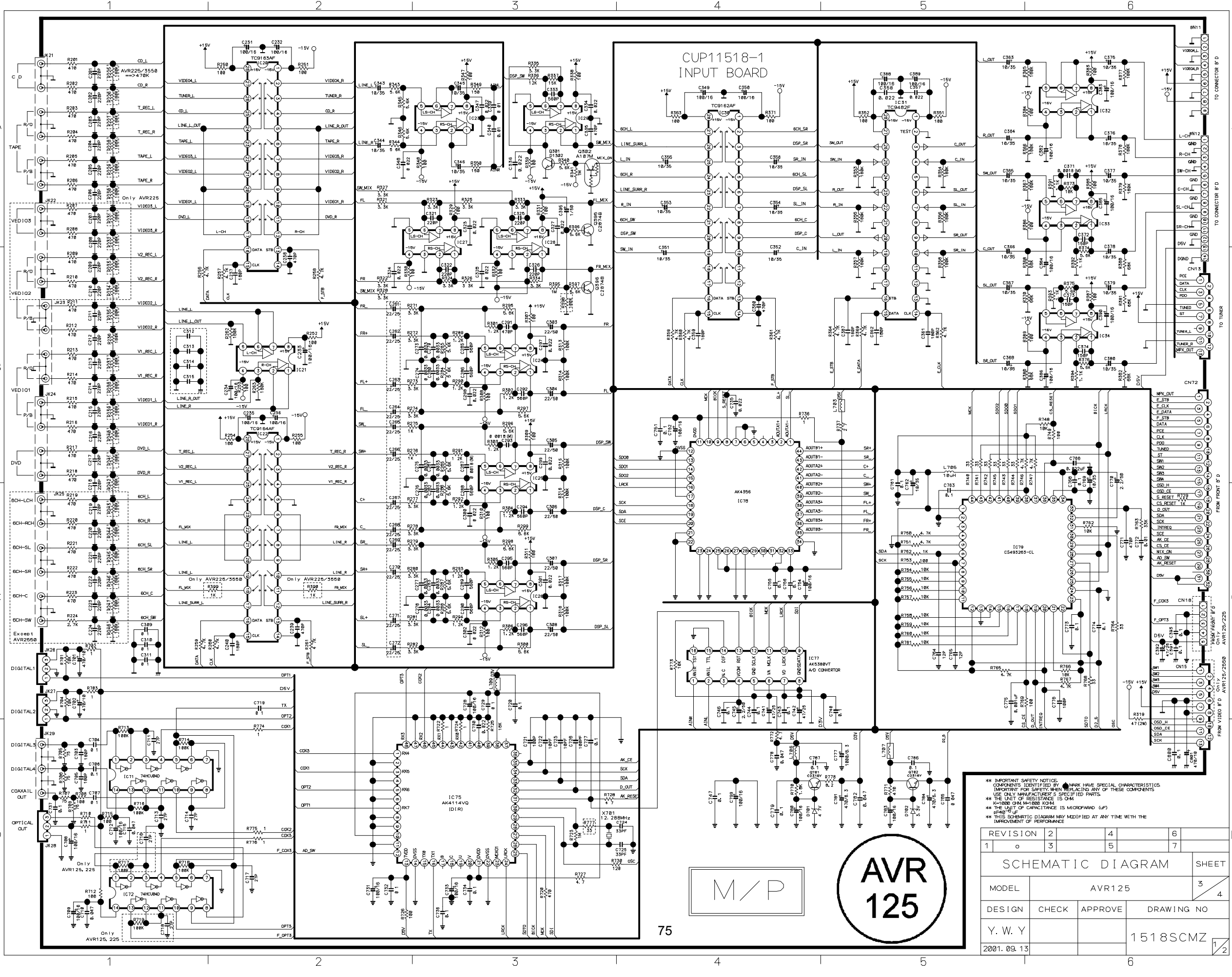

M/P

AVR  
125

\*\* IMPORTANT SAFETY NOTICE:  
COMPONENTS IDENTIFIED BY MARK HAVE SPECIAL CHARACTERISTICS  
IMPORTANT FOR SAFETY WHEN REPLACING ANY OF THESE COMPONENTS  
USE ONLY MANUFACTURER'S SPECIFIED PARTS  
\*\* THE UNIT OF RESISTANCE IS OHM  
\*\* K=1000 OHM M=10000 OHM  
\*\* THE UNIT OF CAPACITANCE IS MICROFARAD (UF)  
\*\* THE LOGIC SYMBOLS ARE MODIFIED AT ANY TIME WITH THE  
IMPROVEMENT OF PERFORMANCE

REVISION		2	4	6
1	o	3	5	7
SCHEMATIC DIAGRAM				SHEET
MODEL				AVR125
DESIGN				3
Y. W. Y	CHECK	APPROVE	DRAWING NO	
			1518SCMZ	
2001.09.13				

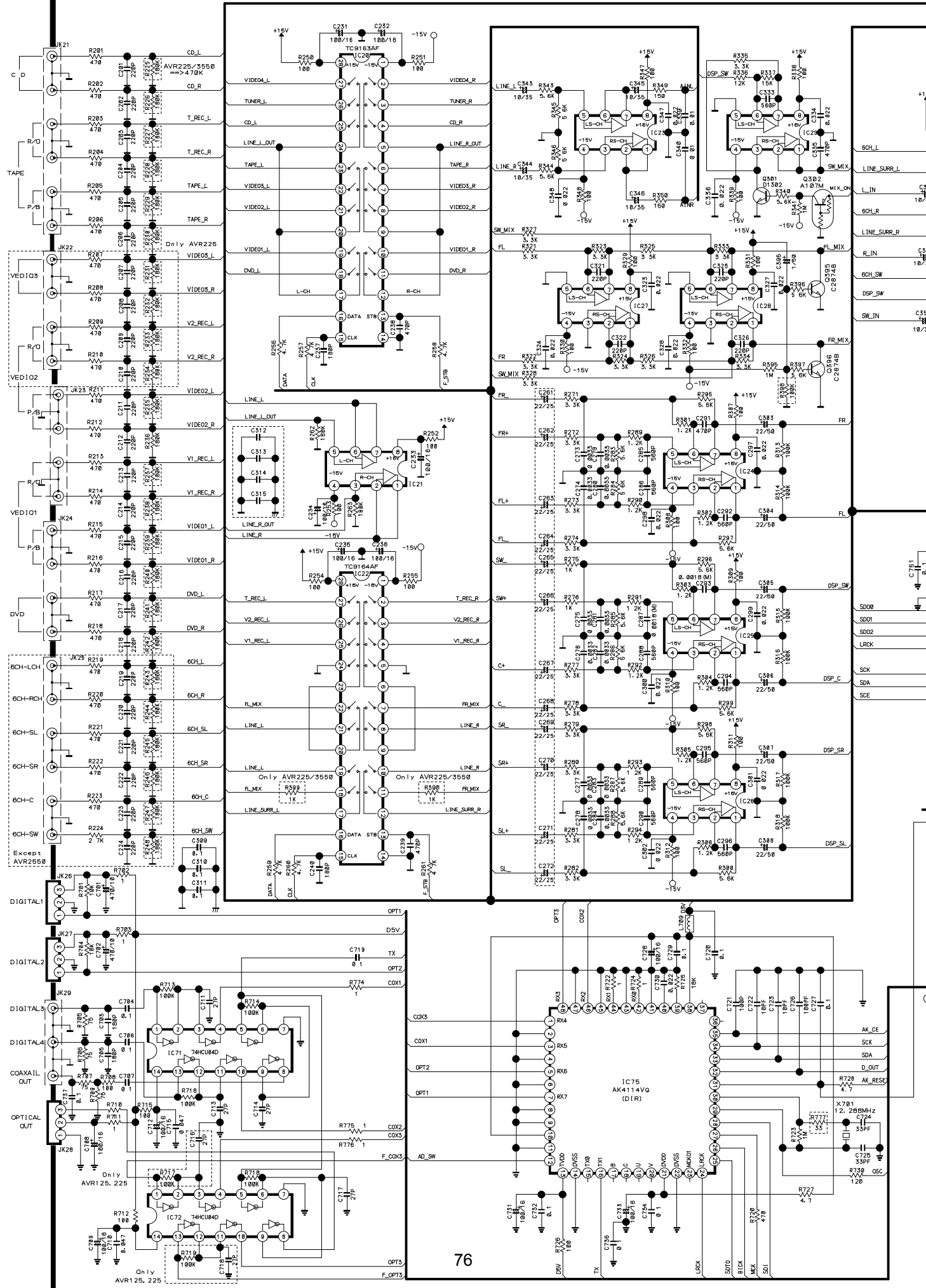



# CUP11518-1 INPUT BOARD

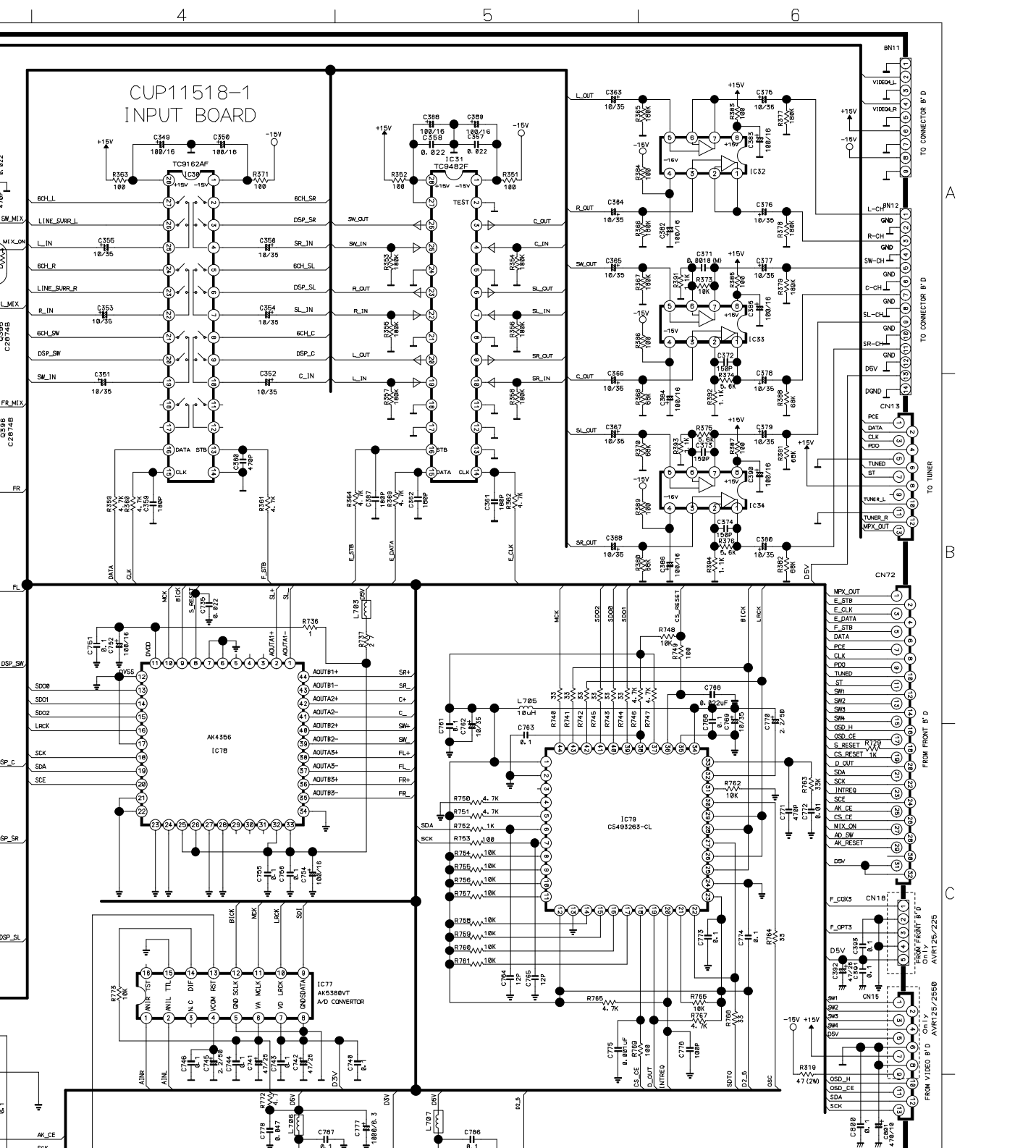

M/P

**AVR  
125**

**\*\* IMPORTANT SAFETY NOTICE:**  
COMPONENTS IDENTIFIED BY \* MARK HAVE SPECIAL CHARACTERISTICS  
IMPORTANT FOR SAFETY, WHEN REPLACING ANY OF THESE COMPONENTS,  
USE ONLY MANUFACTURER'S SPECIFIED PARTS.  
\* THE UNIT OF RESISTANCE IS OHM.  
\* K=1000 OHM, M=1000 KΩ, H=10000 OHM.  
\* P=100 PUF.  
\* THIS SCHEMATIC DIAGRAM MAY MODIFIED AT ANY TIME WITH THE  
IMPROVEMENT OF PERFORMANCE.

REVISION	2	4	6
1	o	3	5
SCHEMATIC DIAGRAM			
MODEL	AVR125		
DESIGN	CHECK	APPROVE	DRAWING NO
Y. W. Y			1518SCMZ
2001.09.13			





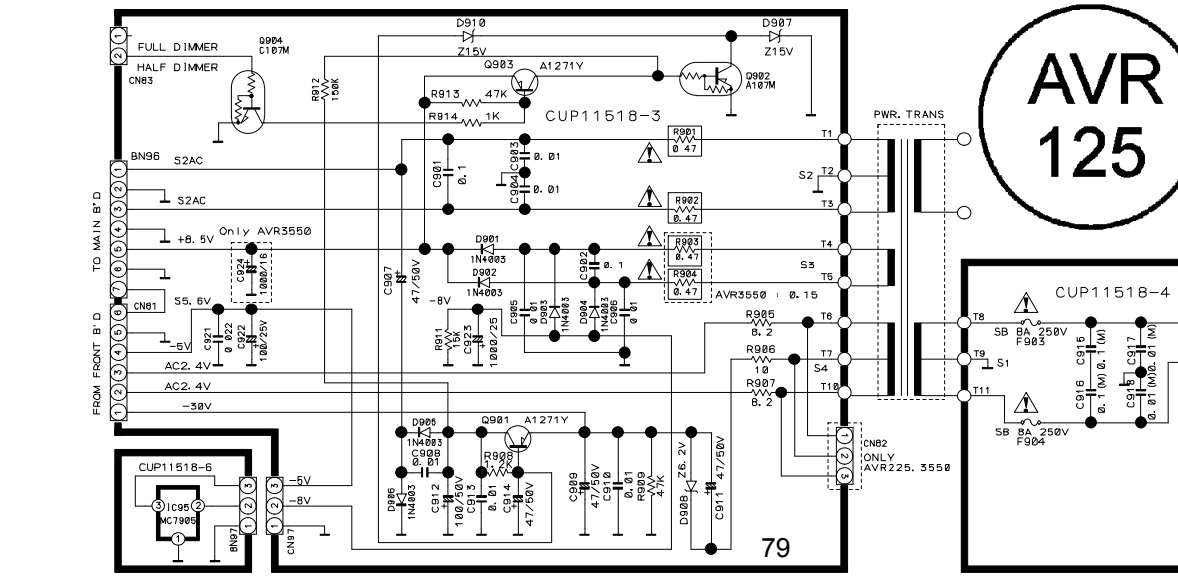
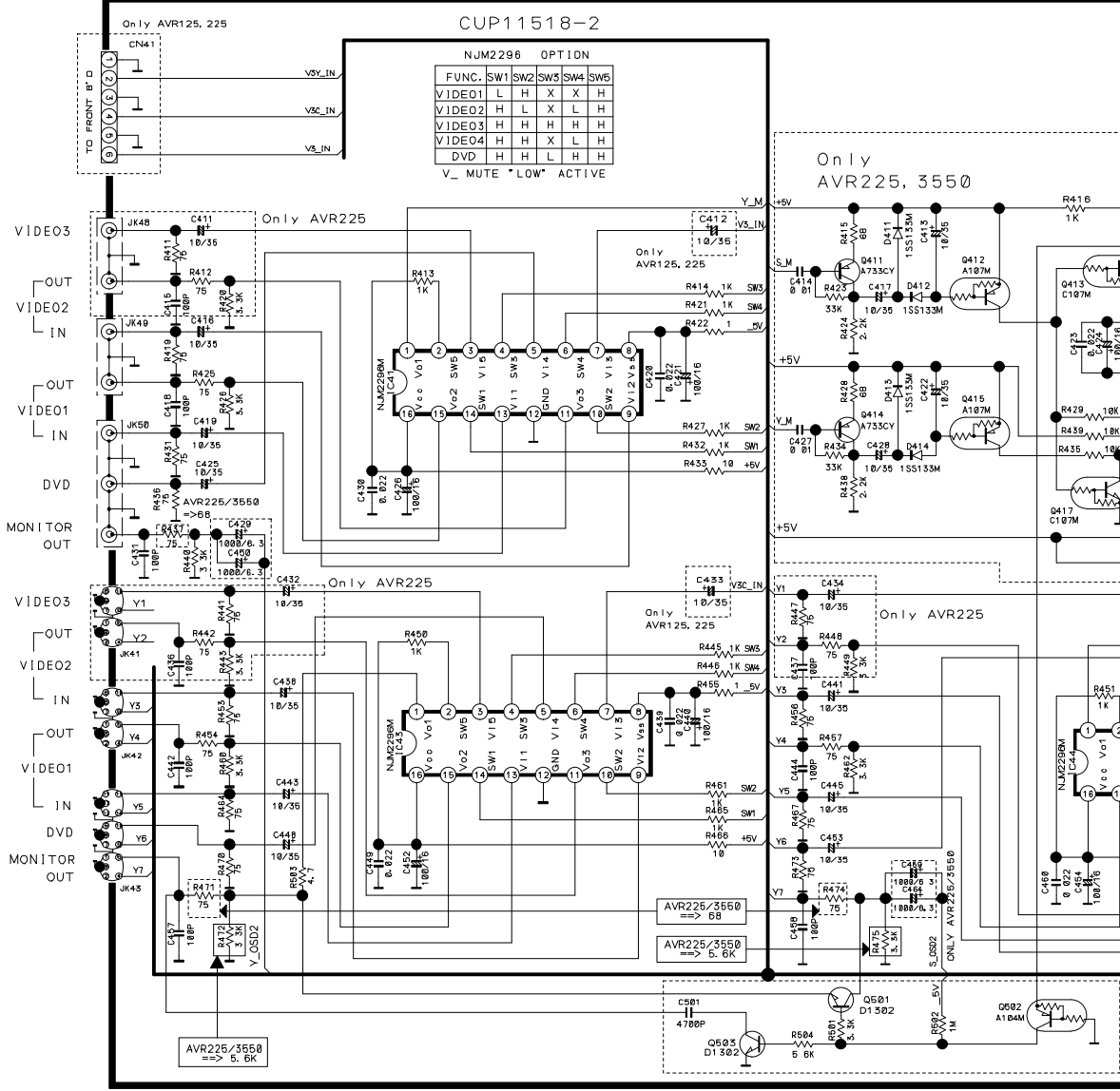



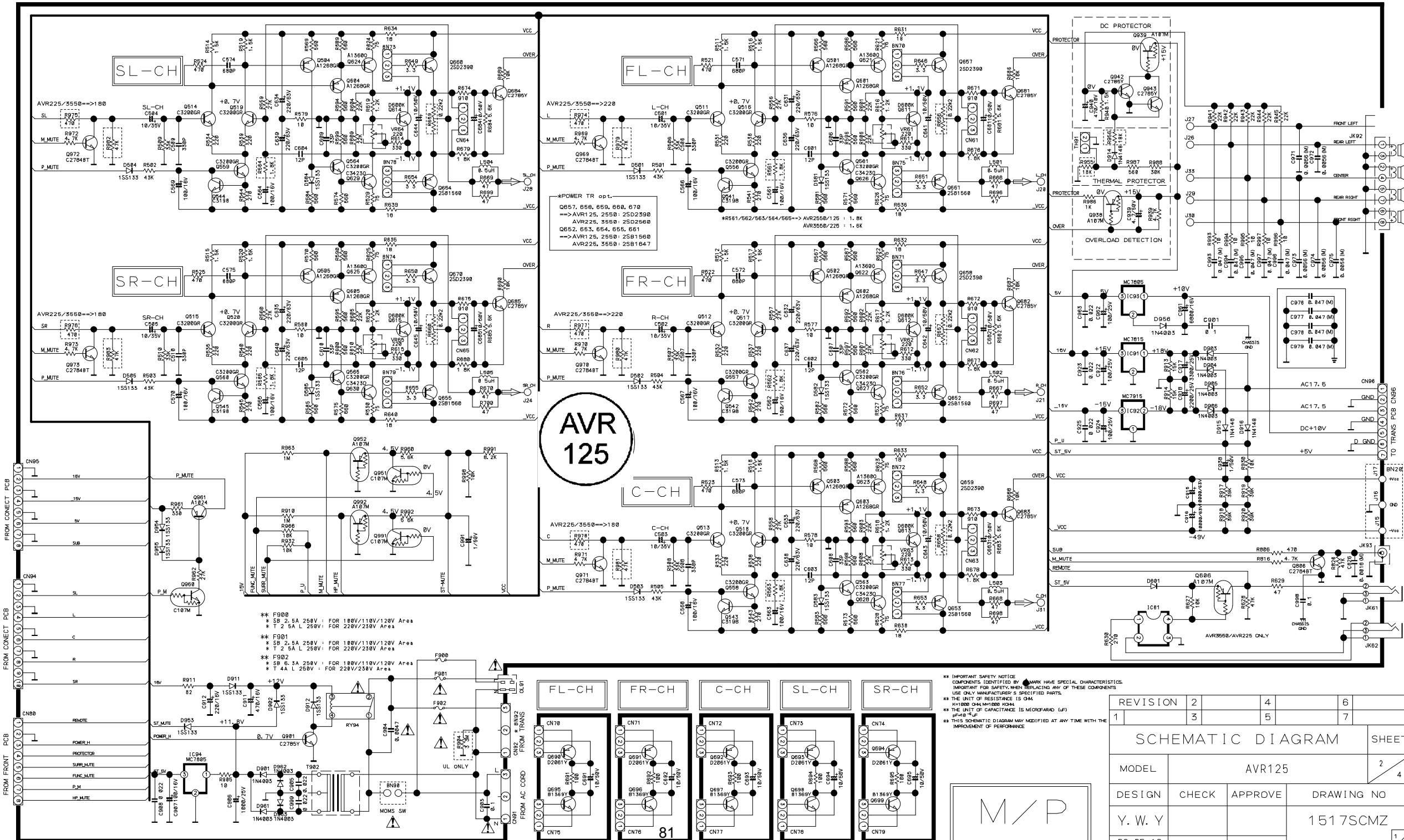

**AVR 125**

\*POWER TR opt.  
 Q657, 658, 659, 660, 670  
 →AVR125, 2550: 2SD2590  
 AVR225, 3550: 2SD2560  
 Q652, 653, 654, 655, 661  
 →AVR125, 2550: 2SB1560  
 AVR225, 3550: 2SB1647

\*\* F900  
 \* SB 2.5A 250V : FOR 180V/110V/120V Area  
 \* T 2.5A L 250V : FOR 220V/230V Area

\*\* F901  
 \* SB 2.5A 250V : FOR 180V/110V/120V Area  
 \* T 2.5A L 250V : FOR 220V/230V Area

\*\* F902  
 \* SB 6.3A 250V : FOR 180V/110V/120V Area  
 \* T 4A L 250V : FOR 220V/230V Area

\*\* IMPORTANT SAFETY NOTICE  
 COMPONENTS IDENTIFIED BY MARK HAVE SPECIAL CHARACTERISTICS.  
 IMPORTANT FOR SAFETY WHEN REPLACING ANY OF THESE COMPONENTS  
 USE ONLY MANUFACTURER'S SPECIFIED PARTS.  
 \*\* THE UNIT OF RESISTANCE IS OHM  
 \*\* THE UNIT OF CAPACITANCE IS MICROFARAD (UF)  
 \*\* IF "S" IS  
 \*\* THIS SCHEMATIC DIAGRAM MAY MODIFIED AT ANY TIME WITH THE  
 IMPROVEMENT OF PERFORMANCE

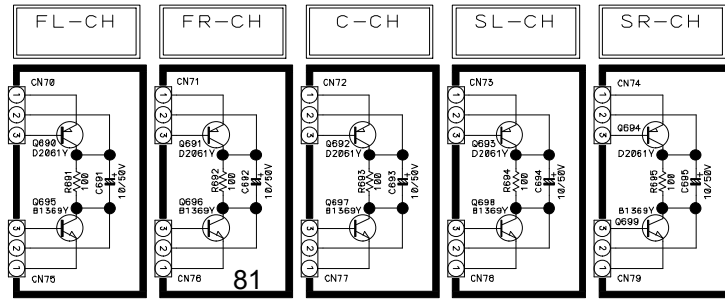

REVISION	2	4	6	
1	3	5	7	
SCHEMATIC DIAGRAM				SHEET
MODEL	AVR125			2
DESIGN	CHECK	APPROVE	DRAWING NO	
Y. W. Y			1517SCMZ	
02.05.16				1/1

M/P

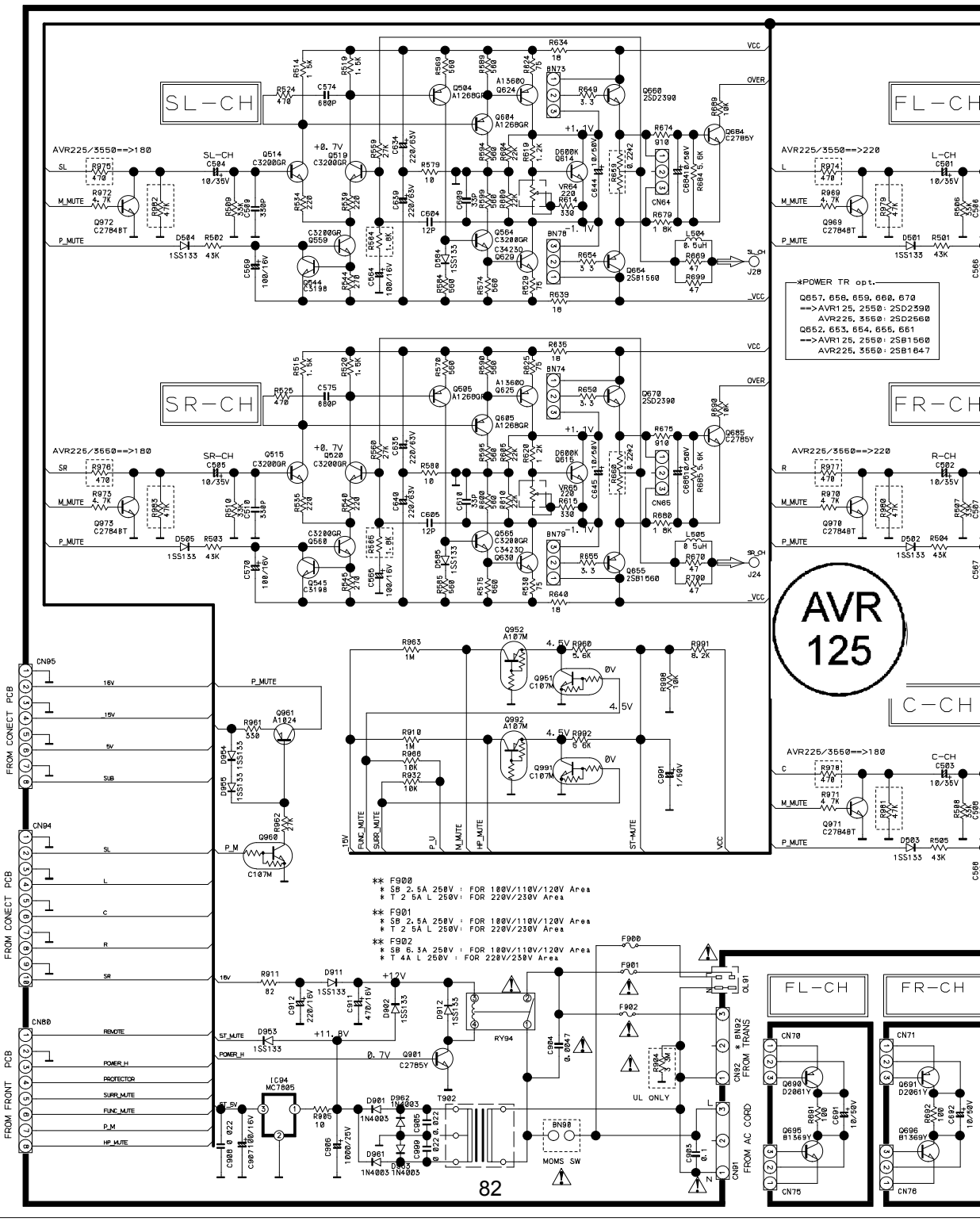

SL-CH

FL-CH

SR-CH

FR-CH

AVR  
125

C-CH

FL-CH

FR-CH

- \*\* F908
- \* SB 2.5A 250V : FOR 180V/110V/120V Area
- \* T 2.5A L 250V : FOR 220V/230V Area
- \*\* F901
- \* SB 2.5A 250V : FOR 180V/110V/120V Area
- \* T 2.5A L 250V : FOR 220V/230V Area
- \*\* F902
- \* SB 6.3A 250V : FOR 180V/110V/120V Area
- \* T 4A L 250V : FOR 220V/230V Area

# AVR 125

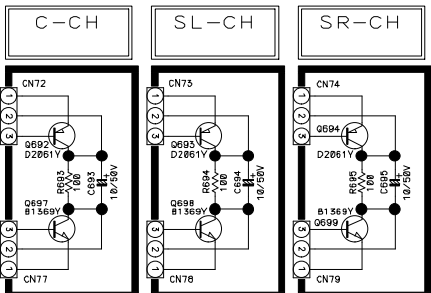
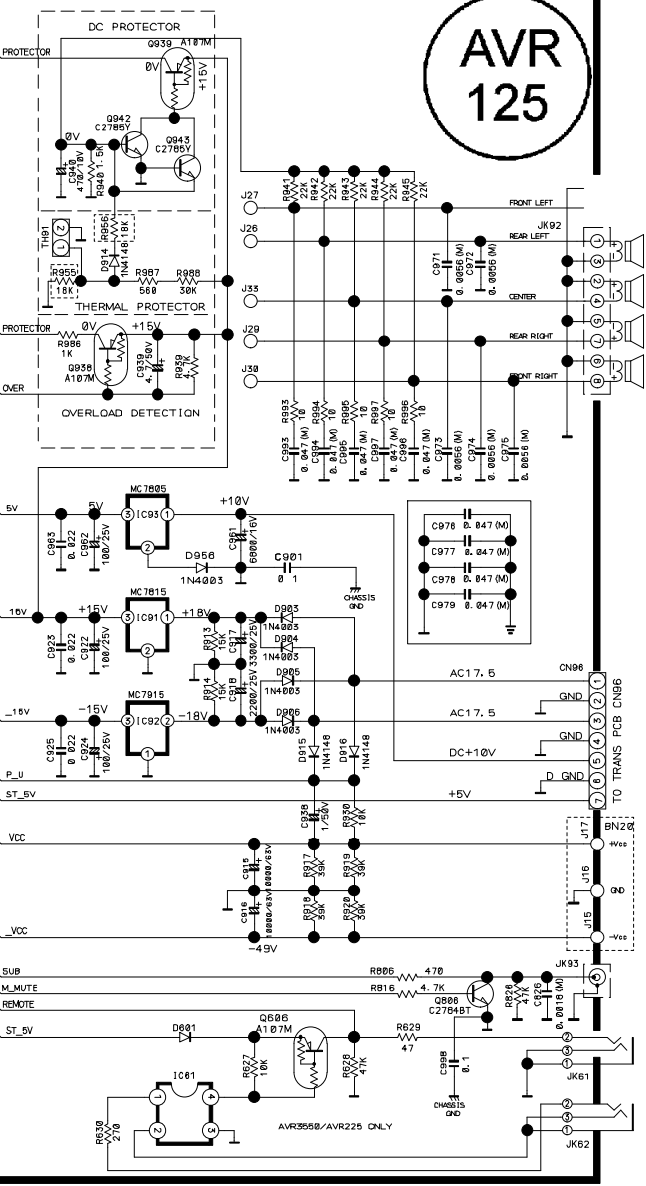
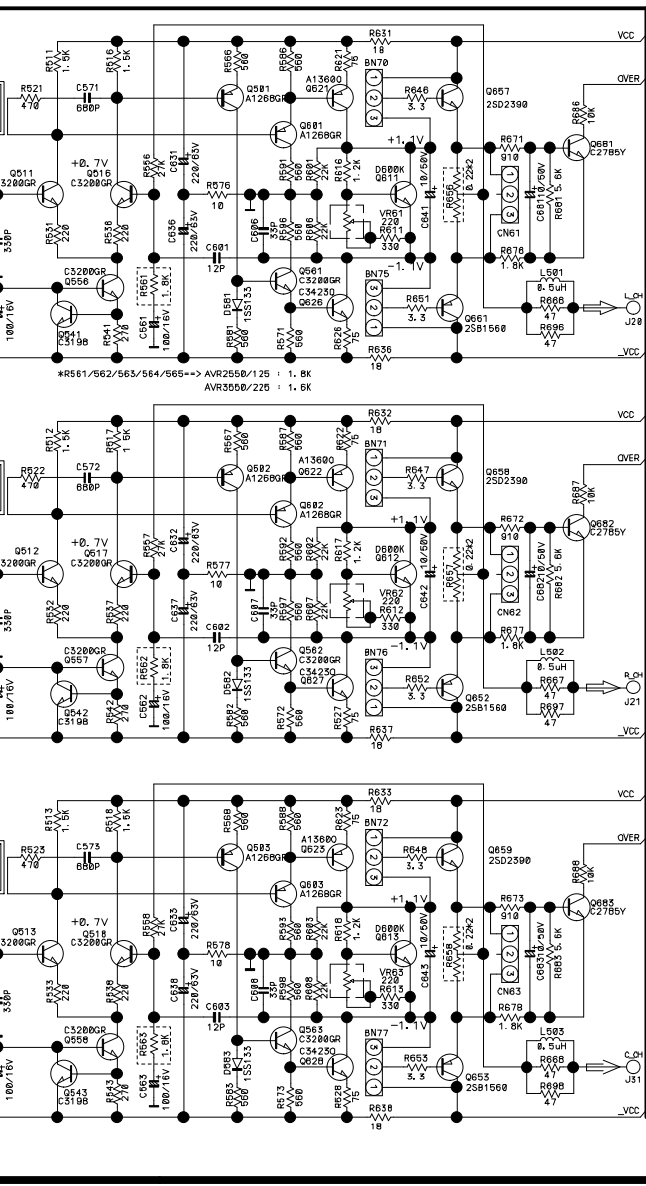

\*\* IMPORTANT SAFETY NOTICE  
 COMPONENTS IDENTIFIED BY MARK HAVE SPECIAL CHARACTERISTICS.  
 IMPORTANT FOR SAFETY, WHEN REPLACING ANY OF THESE COMPONENTS  
 USE ONLY MANUFACTURER'S SPECIFIED PARTS.  
 \*\* THE UNIT OF RESISTANCE IS OHM.  
 K=1000 OHM, M=1000 KHZ.  
 \*\* THE UNIT OF CAPACITANCE IS MICROFARAD (UF)  
 P=10<sup>-6</sup> UF.  
 \*\* THIS SCHEMATIC DIAGRAM MAY MODIFIED AT ANY TIME WITH THE  
 IMPROVEMENT OF PERFORMANCE.

REVISION	2	4	6	
	3	5	7	
SCHEMATIC DIAGRAM				SHEET
MODEL	AVR125			2 4
DESIGNER	CHECK	APPROVE	DRAWING NO	
Y. W. Y			1517SCMZ	
02.05.16				



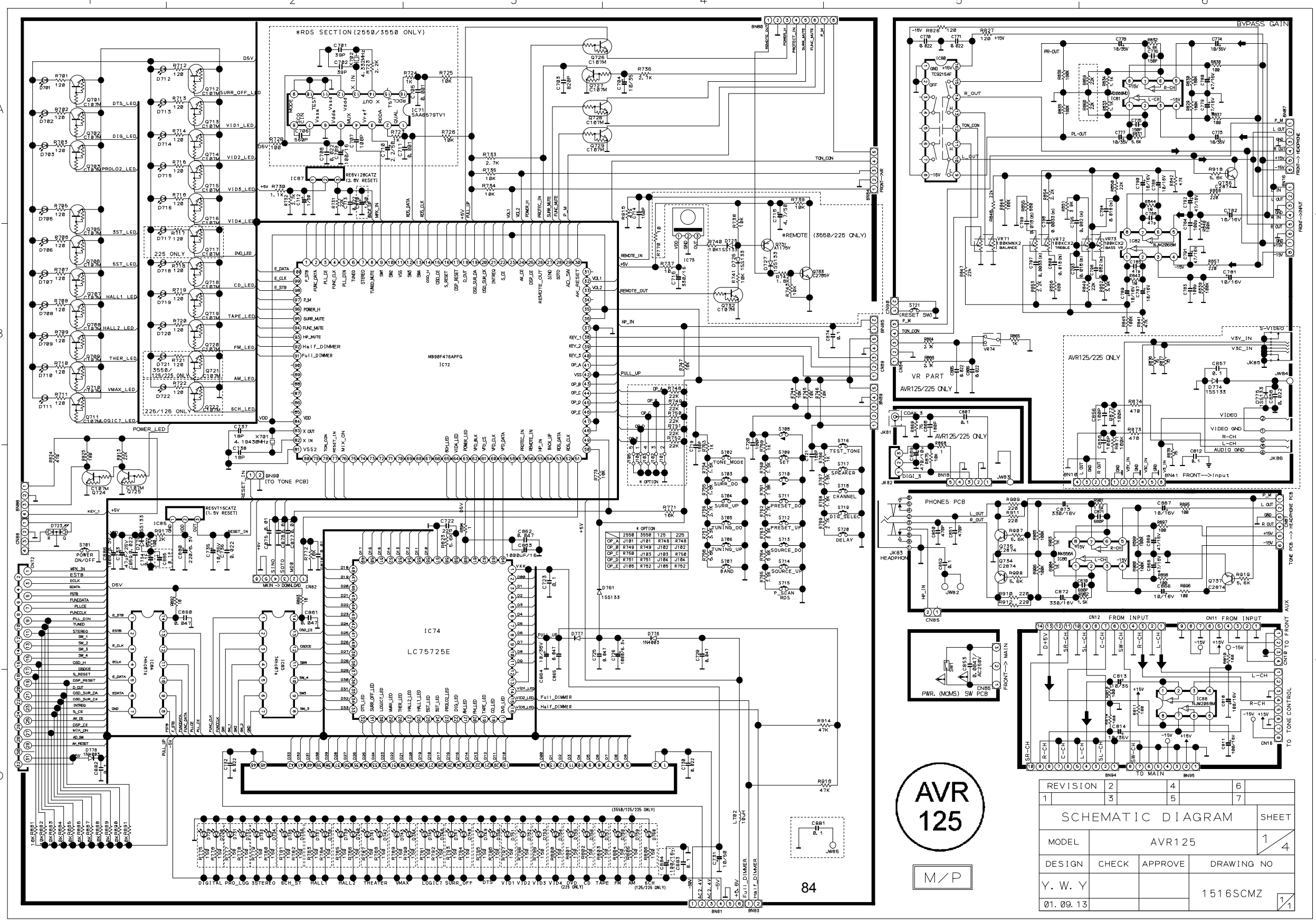

**AVR 125**

M/P

REVISION		2	4	6
1	3	5	7	
SCHEMATIC DIAGRAM				SHEET
MODEL	AVR125			1/4
DESIGN	CHECK	APPROVE	DRAWING NO	
Y. W. Y			1516SCMZ	
01.09.13			1	

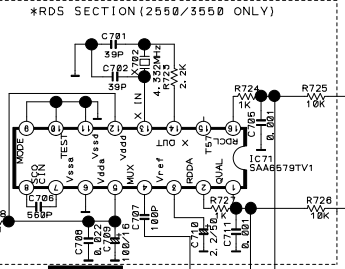
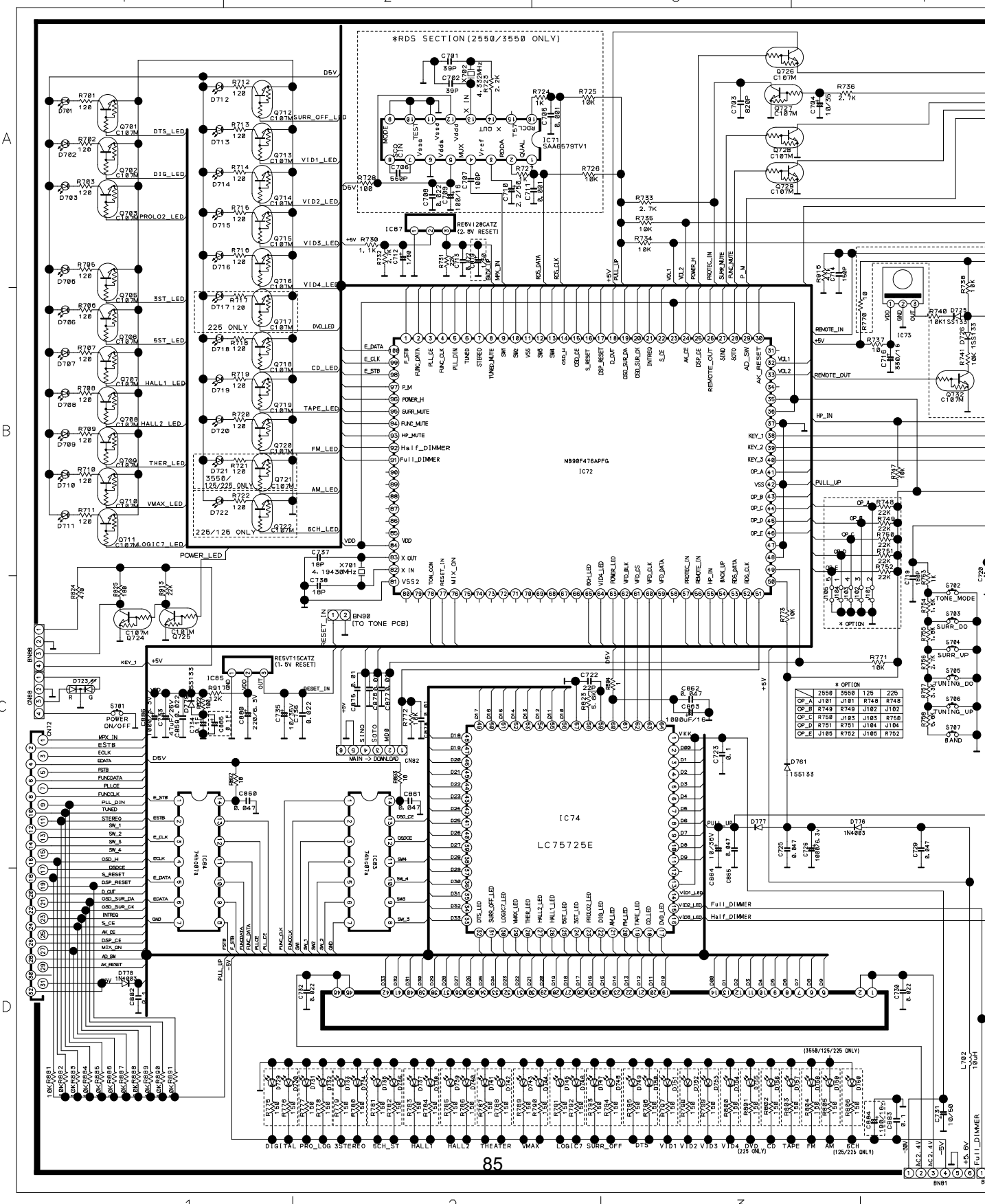

**\* OPTION**

OP-A	2550	3550	125	225
OP-B	101	101	1748	1748
OP-C	1748	1748	1102	1102
OP-D	1751	1751	1164	1164
OP-E	1102	1102	1102	1102



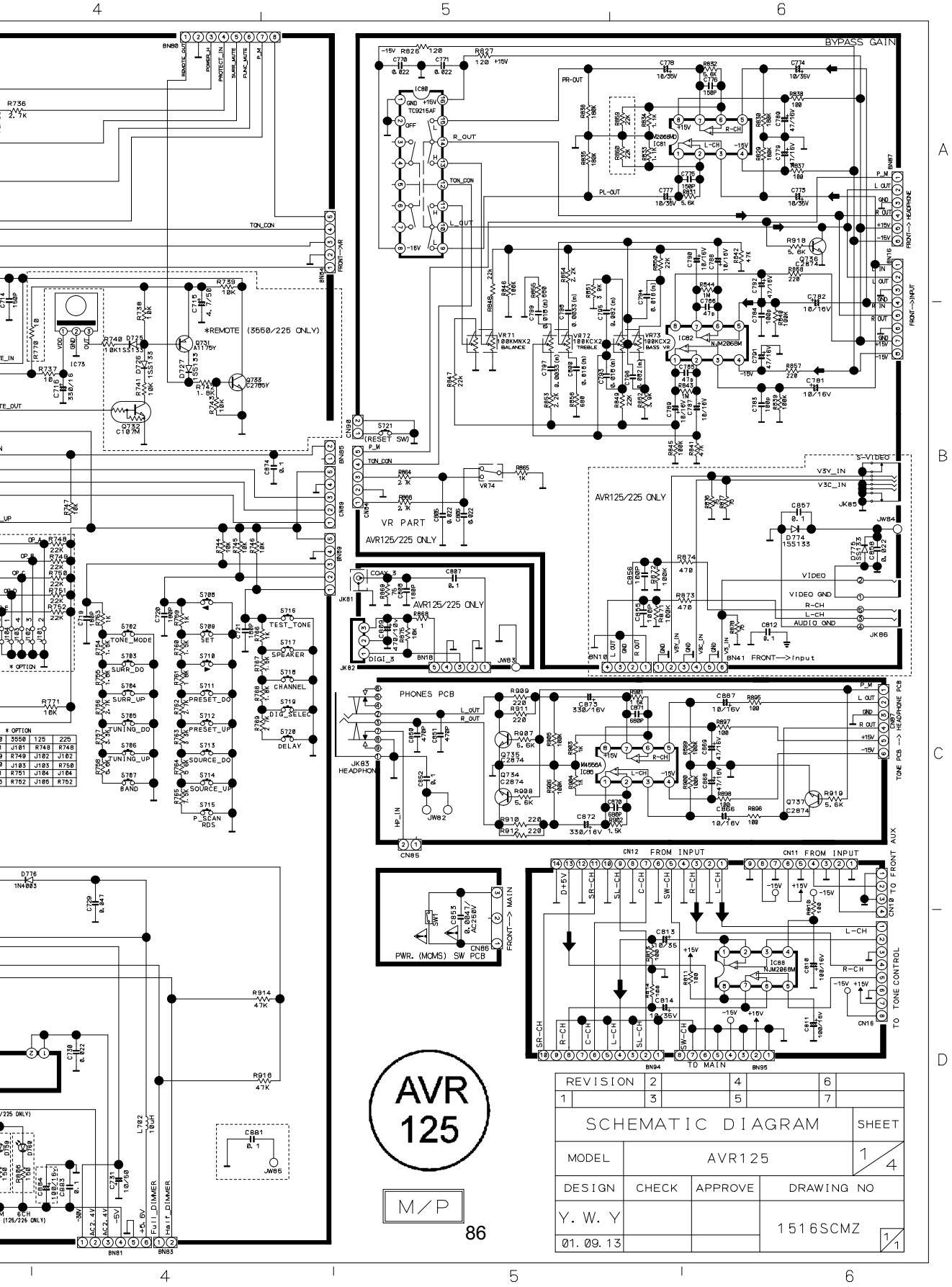

# AVR 125

M/P

REVISION	2	4	6	8
	1	3	5	7
SCHEMATIC DIAGRAM				
MODEL	AVR125			1
DESIGN	CHECK	APPROVE	DRAWING NO	
Y. W. Y			1516SCMZ	
01.09.13			1	

# AVR125 WIRING DIAGRAM

AVR2550/3550 (EUR) : 230V 50Hz  
 AVR125/225 (T/C) : 120V 60Hz

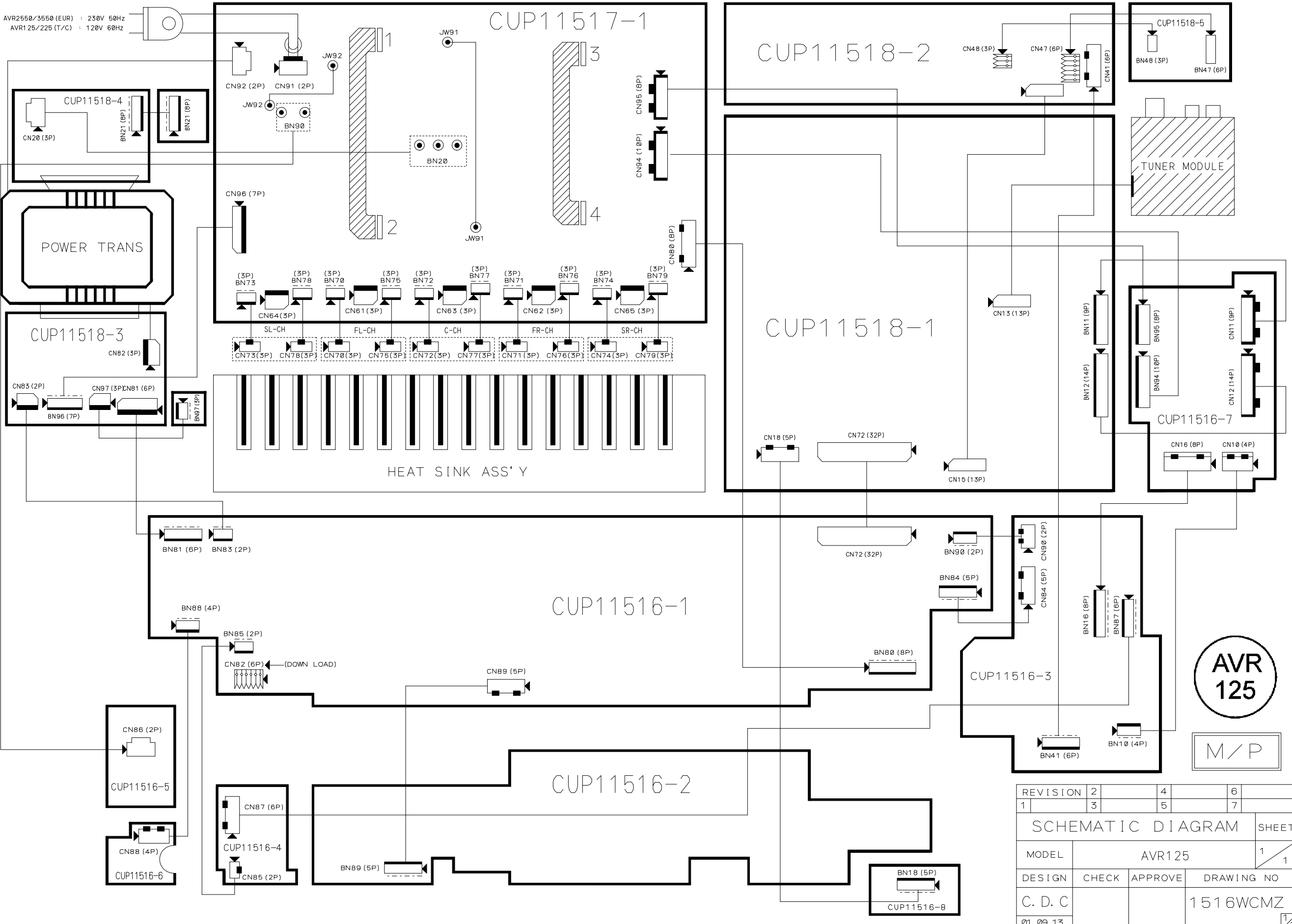

M/P

REVISION	2	4	6	
1	3	5	7	
SCHEMATIC DIAGRAM				SHEET
MODEL			AVR125	1/1
DESIGN	CHECK	APPROVE	DRAWING NO	
C. D. C			1516WCMZ	
01.09.13			1/1	

### 1. Instruction manual ass'y - Accessories

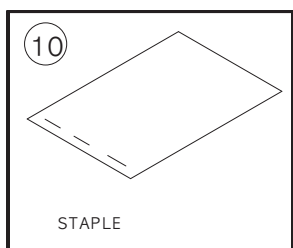
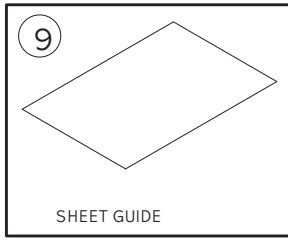
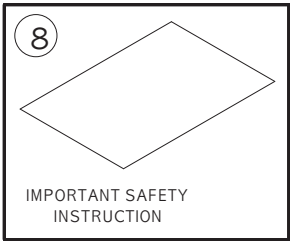
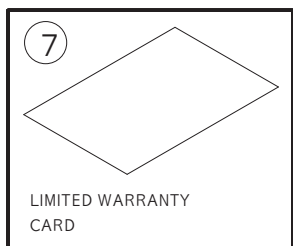
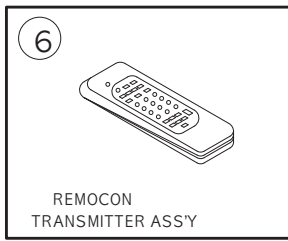
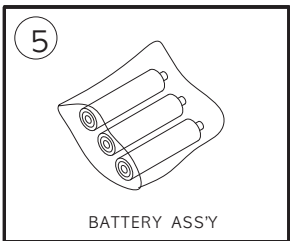
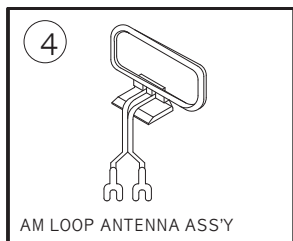
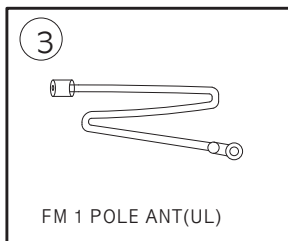
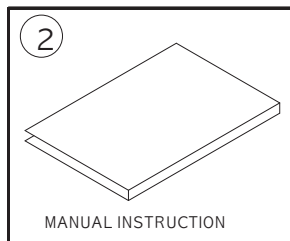
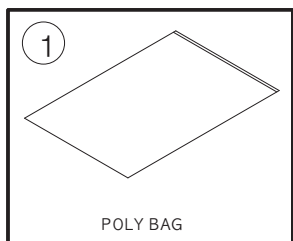

NO	DESCRIPTION	PART NO.	Q.ty
1	POLY BAG		1
2	INSTRUCTION MANUAL	CQX1A778Z	1
3	FM 1 POL ANT(UL)	CSA1A019Z	1
4	AM LOOP ANTENNA ASS'Y	CSA3A012Z	1
5	BATTERY		3
6	REMOCON TRANSMITTER ASS'Y	HARTAVR125CC	1
7	LIMITED WARRANTY CARD	CQE1A172Y	1
8	IMPORTANT SAFETY INSTRUCTION	CQE1A169Z	1
9	SHEET GUIDE	CQE1A188Z	1
10	STAPLE		3

### 2. Package Drawing

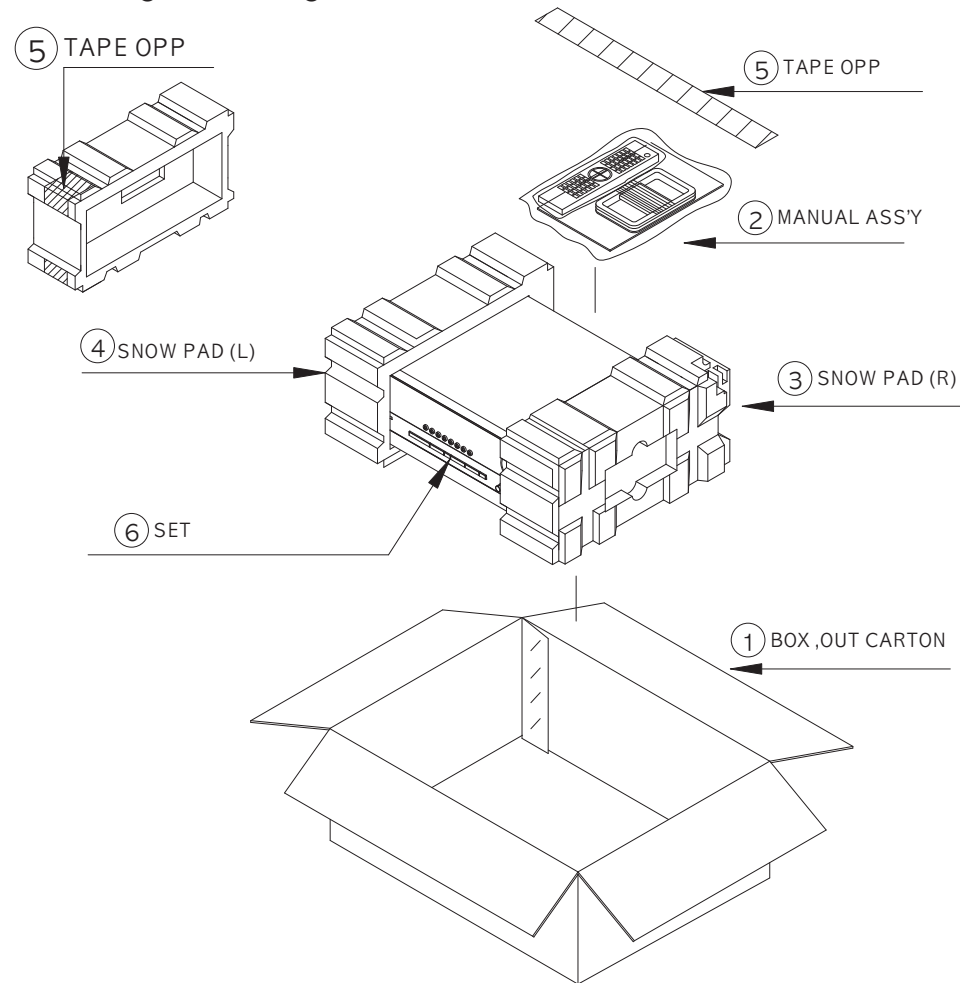

NO	DESCRIPTION	PART NO.	Q.ty
1	BOX,OUT CARTON	CPG1A677X	1
2	MANUAL ASS'Y		1
3	SNOW,PAD(R)	CPS4A565	1
4	SNOW,PAD(L)	CPS4A564	1
5	CELLO OPP TAPE		0.8M
5	SET		1